

## MicroHAWK V430-F Autofocus Multicode Reader

**Kreski**

Zapraszamy do kontaktu!  
Więcej informacji: [www.kreski.pl](http://www.kreski.pl)

### Autofocus to read codes at different distances.

- Simple configuration with WebLink.
- 5 megapixel sensor available.
- Autofocus available.
- Alternate LED configuration available.
- Smallest in class.
- IP65 / IP67.
- Ethernet TCP/IP, EtherNet/IP, and PROFINET.



## MicroHAWK V430-F

### Mounting Options

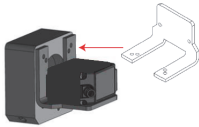
Appearance	Type	Part Number
	L Bracket Adjustable Angle Mounting Kit	V430-AM0
	1/4-20 Camera Mounting Block Kit	V430-AM1
	4" (102 mm) Ram Mount Stand	V430-AM2
	APG Pan and Tilt Camera Mount	V430-AM3
	Nylon Screw and Washer Electrical Isolation Mounting Kit	V430-AM4
	MS-4 / MINI to V/F4XX-F Adapter Plate	V430-AM5
	Smart Ring Light to V/F4XX-F Mounting Bracket	V430-AM6
	QX / Vision HAWK to V/F4XX-F Adapter Plate	V430-AM7

## Optics Options

Appearance	Type	Part Number
	Front Window Installation Kit	V430-AF10 *
	Diffuser Installation Kit	V430-AF11 *
	Polarizer Installation Kit	V430-AF12 *
	Right Angle Mirror Installation Kit	V430-AF3
	YAG Filter Installation Kit	V430-AF4
	ESD-Safe Window Installation Kit	V430-AF5
	Red Filter Installation Kit	V430-AF6
	Blue Filter Installation Kit	V430-AF7





\* Note: V430-AF10, AF11, and AF12 are used for **MicroHAWK V/F4X0-FXXXXXXX-XXX** readers in this datasheet. The prior generation **MicroHAWK V430-FXXXXXXX** code reader uses part numbers V430-AF0, AF1, and AF2. Please select the correct accessory from the table based on your camera part number format.

Accessory	Prior V430-FXXXXXXX Code Reader	New V/F4X0-FXXXXXXX-XXX Code Reader and Smart Camera
Front Window Installation Kit	V430-AF0	V430-AF10
Diffuser Installation Kit	V430-AF1	V430-AF11
Polarizer Installation Kit	V430-AF2	V430-AF12



Zapraszamy do kontaktu!  
Więcej informacji: [www.kreski.pl](http://www.kreski.pl)

**Additional Optics Options**

Product	Appearance	Type	Part Number
<b>V430-F Window Kits</b> 		Front Window Installation Kit	<b>V430-AF0R</b>
		Diffuser Installation Kit	<b>V430-AF1R</b>
		Polarizer Installation Kit	<b>V430-AF2R</b>

**Front Window Installation Kit  
V430-AF0R**

**Diffuser Installation Kit  
V430-AF1R**

**Polarizer Installation Kit  
V430-AF2R**



**Red Ring Light Installation Kit  
V430-ALRR**

**White Ring Light Installation Kit  
V430-ALWR**

**Blue Ring Light Installation Kit  
V430-ALBR**

**IR Ring Light Installation Kit  
V430-ALIR**

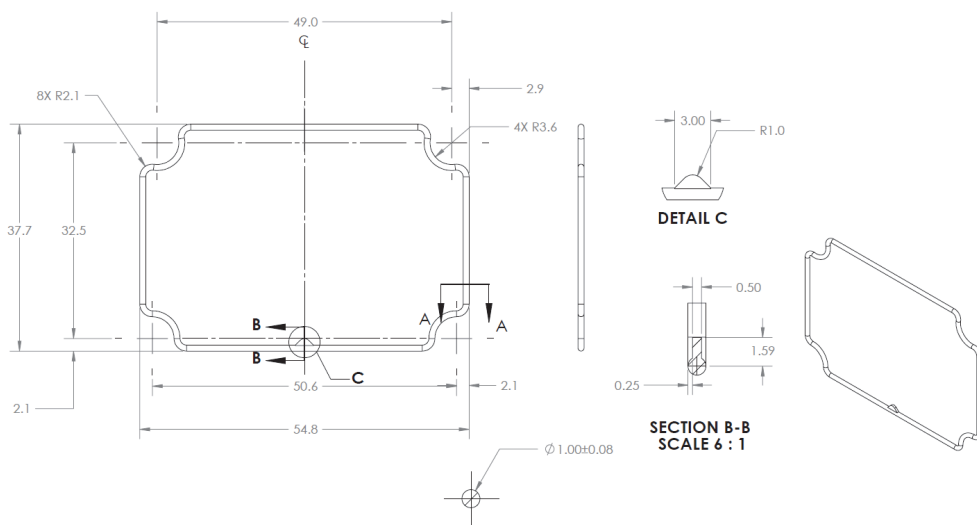
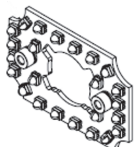

**Lighting Options**

Product	Appearance	Type	Part Number
<b>V430-F Ring Light Kits</b> 		Red Ring Light Installation Kit	<b>V430-ALRR</b>
		White Ring Light Installation Kit	<b>V430-ALWR</b>
		Blue Ring Light Installation Kit	<b>V430-ALBR</b>
		IR Ring Light Installation Kit	<b>V430-ALIR</b>

**Additional Lighting Options**

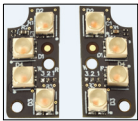
Appearance	Type	Part Number
	Red Light Installation Kit	<b>V430-ALR</b>
	White Light Installation Kit	<b>V430-ALW</b>
	Blue Light Installation Kit	<b>V430-ALB</b>
	IR Light Installation Kit	<b>V430-ALI</b>

**Kreski**  
 Zapraszamy do kontaktu!  
 Więcej informacji: [www.kreski.pl](http://www.kreski.pl)

## Wiring Options

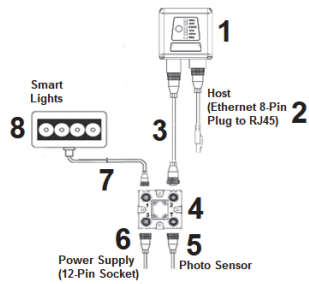

Drawing Reference	Appearance	Category	Length / Spec	Part Number
2		Ethernet Communication Cables – Straight Connectors M12 Plug on Camera to RJ45 Connector	1 Meter	<b>V430-WE-1M</b>
			3 Meters	<b>V430-WE-3M</b>
			5 Meters	<b>V430-WE-5M</b>
		Ethernet Communication Cables – Right Angle M12 Connectors* M12 Plug on Camera to RJ45 Connector	3 Meters – Right Angle Up*	<b>V430-WELU-3M</b>
			3 Meters – Right Angle Down*	<b>V430-WELD-3M</b>
3		Camera to QX-1 Interconnect Cables M12 Socket to M12 Plug QX-1 is used as breakout module for common IO signals and power.	1 Meter	<b>V430-WQ-1M</b>
		M12 Socket to M12 Plug, with Power Filter	300 mm	<b>V430-WQF-1M</b>
		Camera to QX-1 Interconnect Cables M12 Socket to M12 Plug QX-1 is used as breakout module for common IO signals and power.	3 Meters	<b>V430-WQ-3M</b>
			5 Meters	<b>V430-WQ-5M</b>
4		QX-1 Interconnect Module – Power, Trigger, Smart Light Control Breakout		<b>98-000103-02</b>
5		QX-1 Photo Sensor, M12 4-Pin Plug, NPN	2 Meters – Light ON/ Dark ON	<b>99-9000016-01</b>
		QX-1 Field-Wireable M12 4-Pin Plug for Any Trigger Source or Photo Sensor	Screw Terminals	<b>98-9000239-01</b>
6		Power Supply, 100-240VAC, +24VDC, M12 12-Pin Socket	1 Meter US/Euro Plug	<b>97-000012-01</b>
7		QX-1 M12 to Smart Light Power and Strobe Control Cables	3 Meters – Continuous Power	<b>61-000204-01</b>
		M12 Plug on QX-1 to 5 Pin Socket on light	3 Meters – Strobe Control	<b>61-000218-01</b>
8		Omron Microscan Smart Light Series	Integrated Power and Strobe Control Module	<b>See Omron Microscan Smart Light Offering - Ring, DOAL, Large Area Lighting</b>

\* Right angle cables.

Right angle up

Right angle down



**Wiring Examples**

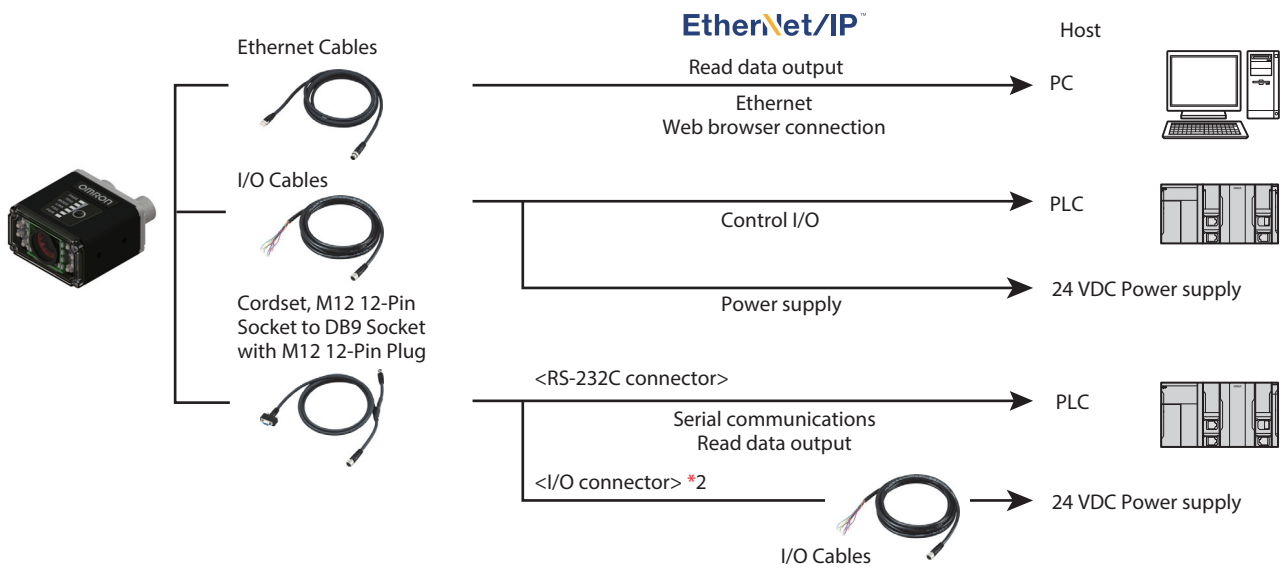

**Kreski**

Zapraszamy do kontaktu!  
Więcej informacji: [www.kreski.pl](http://www.kreski.pl)

## Alternate Wiring Options

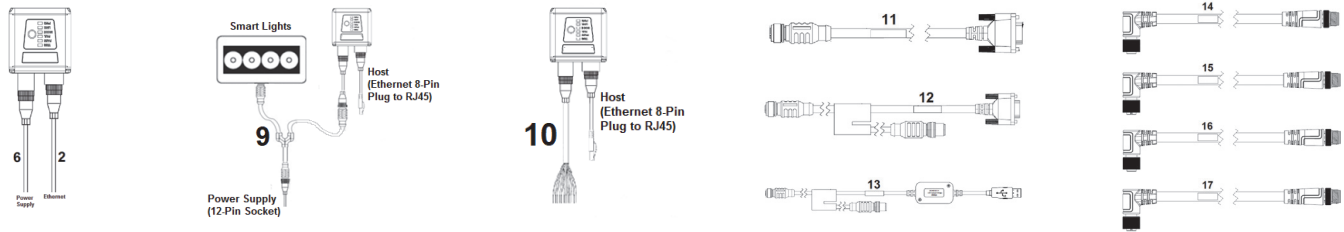

Drawing Reference	Appearance	Category	Length / Spec	Part Number
9		Y Cable, Camera/Power and Smart Light Power (Continuous On)	1 Meter	61-9000135-01
		Y Cable, Camera/Power and Smart Light Strobe Control	1 Meter	61-9000137-01
10		M12 to Flying Leads Cable, Straight Power, IO, RS-232, USB	3 Meters	V430-W8-3M
		M12 to Flying Leads Cable, with Power Filter		V430-W8F-3M
		M12 to Flying Leads Cable, Straight Power, IO, RS-232, USB	5 Meters	V430-W8-5M
		M12 to Flying Leads Cable, with Power Filter		V430-W8F-5M
		M12 to Flying Leads Cable Right Angle Power, IO, RS232, USB	3 Meters – Right Angle Up	V430-W8LU-3M
		M12 to Flying Leads Cable Right Angle, with Power Filter		V430-W8LUF-3M
		M12 to Flying Leads Cable Right Angle Power, IO, RS232, USB	3 Meters – Right Angle Down	V430-W8LD-3M
		M12 to Flying Leads Cable Right Angle, with Power Filter		V430-W8LDF-3M
11		M12 to RS-232 Breakout	1 Meter	V430-WR-1M
			3 Meters	V430-WR-3M
12		Camera to QX-1 Interconnect Cables with RS-232 Breakout	2.7 Meters	V430-WQR-3M
13		Camera to QX-1 Interconnect Cables with USB Keyboard Wedge Breakout	2.7 Meters	V430-WQK-3M
14		M12 12-Pin Plug to M12 12-Pin Socket, Right Angle	3 Meters	61-000148-03
15		M12 12-Pin Plug to M12 12-Pin Socket, Right Angle, Alternate Key	3 Meters	61-000148-04
16		M12 12-Pin Plug to M12 12-Pin Socket, Right Angle	1 Meter	61-000162-03
17		M12 12-Pin Plug to M12 12-Pin Socket, Right Angle, Alternate Key	1 Meter	61-000162-04

Zapraszamy do kontaktu!  
Więcej informacji: [www.kreski.pl](http://www.kreski.pl)

## V430-F Part Number Structure

Use this legend when defining product part numbers. Please note that not all combinations of parameters are valid. For instance, color cameras are only available with white lighting, and 400 mm fixed focus is only available with UHD lenses. When ordering, use valid part numbers from the tables in the Ordering Information section only.

### V430-F[XXX][Y][ZZZ]-[L][C][P]

Key	Classification	Code	Meaning
<b>XXX</b>	Focus Distance (mm)	000	Autofocus – Variable Distance
		050	Fixed Focus at 50 mm
		064	Fixed Focus at 64 mm
		081	Fixed Focus at 81 mm
		102	Fixed Focus at 102 mm
		133	Fixed Focus at 133 mm
		190	Fixed Focus at 190 mm
		300	Fixed Focus at 300 mm
		400	Fixed Focus at 400 mm
<b>Y</b>	Lens	W	Wide Field of View – 5.2 mm Focal Length Lens
		M	Medium Field of View – 7.7 mm Focal Length Lens
		N	Narrow Field of View – 16 mm Focal Length Lens
		L	Narrow 16 mm Lens – Autofocus to 1160 mm
<b>ZZZ</b>	Sensor	03M	752 x 480 (0.3 MP) Pixel, Mono Sensor, Global Shutter
		12M	1280 x 960 (1.2 MP) Pixel, Mono Sensor, Global Shutter
		50C	2592 x 1944 (5 MP) Pixel, Color Sensor, Rolling Shutter
<b>L</b>	Light Type	N	No Outer Light
		S	Standard Outer Light
		R	Ring Light
<b>C</b>	Light Color	N	No Outer Light
		R	Red
		W	White
<b>P</b>	Software License	P	High Speed, Plus Mode
		X	High Speed, X-Mode

#### Example Part Numbers:

- V430-F081W03M-NNP: Fixed Focus at 81 mm, Wide Lens, 0.3 MP Monochrome Sensor, No Outer Light, High Speed, Plus Mode
- V430-F000N12M-RRX: Autofocus, Narrow Lens, 1.2 MP Mono, Ring Light, Red, High Speed, X-Mode
- V430-F000W50C-SWP: Autofocus, Wide Lens, 5 MP Color, Standard Light, White, High Speed, Plus Mode

## V430-F Valid Product Matrix

Model	Category	Focus Type	Sensor	Lens	Focus Distance (mm)	Light	License
V430-F	Monochrome	Fixed Focus	03M, 12M	W, M	50, 64, 81, 102, 133, 190, 300	None, Red, White	P, X
			12M	N	64, 400	None, Red, White	P, X
		Autofocus	03M	W, M	50 <-> 300 Autofocus	None, Red, White	P, X
			12M	W, M, N	50 <-> 300 (W, M) 40 <-> 150 (N) Autofocus	None, Red, White	P, X
	Color	Fixed Focus	50C	W, M	50, 64, 81, 102, 133, 190, 300	None, White	P, X
		Autofocus	50C	W, M	50 <-> 300 Autofocus	None, White	P, X
	Specialty	Ring Light Autofocus	12M	M, N	50 <-> 300 (M) 40 <-> 150 (N) Autofocus	Red, White (Ring)	X
		Long Range Autofocus	12M	L	75 <-> 1160 Autofocus	None, Red, White	P, X

## V430-F Ordering Information

### Categories:

#### 1. Fixed Focus Camera

- a.) V430-F Monochrome Fixed Focus Camera
- b.) V430-F Color Fixed Focus Camera
- c.) V430-F 1.2 MP Monochrome Fixed Focus Camera with Narrow Lens

#### 2. Autofocus Camera

- a.) V430-F 0.3 MP Monochrome Autofocus Camera (50 - 300 mm)
- b.) V430-F 1.2 MP Monochrome Autofocus Camera (50 - 300 mm for Wide and Medium Lens, 40 - 150 mm for Narrow Lens)
- c.) V430-F Color Autofocus Camera (50 - 300 mm)
- d.) V430-F 1.2 MP Monochrome Autofocus Camera with Ring Light (50 – 300 mm for Medium Lens, 40 - 150 mm for Narrow Lens)
- e.) V430-F 1.2 MP Monochrome Long Range Autofocus Camera (75 - 1160 mm)



### 1a) V430-F Monochrome Fixed Focus Camera: Valid Combinations

V430-F[XXX][Y][ZZZ]-[L][C][P]

Key	Classification	Code	Meaning
XXX	Focus Distance (mm)	050	Fixed Focus at 50 mm
		064	Fixed Focus at 64 mm
		081	Fixed Focus at 81 mm
		102	Fixed Focus at 102 mm
		133	Fixed Focus at 133 mm
		190	Fixed Focus at 190 mm
		300	Fixed Focus at 300 mm
Y	Lens	W	Wide Field of View - 5.2 mm Focal Length Lens
		M	Medium Field of View – 7.7 mm Focal Length Lens
ZZZ	Sensor	03M	752 x 480 (0.3 MP) Pixel, Mono Sensor, Global Shutter
		12M	1280 x 960 (1.2 MP) Pixel, Mono Sensor, Global Shutter
L	Light Type	N	No Outer Light
		S	Standard Outer Light
C	Light Color	N	No Outer Light
		R	Red
		W	White
P	Software License	P	High Speed, Plus Mode
		X	High Speed, X-Mode

### 1b) V430-F 5.0 MP Color Fixed Focus Camera: Valid Combinations

Note: 5 MP Color cameras are available with No Outer Light or White Light options only.

V430-F[XXX][Y]50C-[L][C][P]

Key	Classification	Code	Meaning
XXX	Focus Distance (mm)	050	Fixed Focus at 50 mm
		064	Fixed Focus at 64 mm
		081	Fixed Focus at 81 mm
		102	Fixed Focus at 102 mm
		133	Fixed Focus at 133 mm
		190	Fixed Focus at 190 mm
		300	Fixed Focus at 300 mm
Y	Lens	W	Wide Field of View - 5.2 mm Focal Length Lens
		M	Medium Field of View – 7.7 mm Focal Length Lens
L	Light Type	N	No Outer Light
		S	Standard Outer Light
C	Light Color	N	No Outer Light
		W	White
P	Software License	P	High Speed, Plus Mode
		X	High Speed, X-Mode



**1c) V430-F 1.2 MP Monochrome Fixed Focus Camera with Narrow Lens: Valid Combinations**

**Note:** Fixed Focus Narrow lens option available for 1.2 MP Mono camera only.

**V430-F[XXX]N12M-[L][C][P]**

Key	Classification	Code	Meaning
XXX	Focus Distance (mm)	064	Fixed Focus at 64 mm
		400	Fixed Focus at 400 mm
L	Light Type	N	No Outer Light
		S	Standard Outer Light
C	Light Color	N	No Outer Light
		R	Red
		W	White
P	Software License	P	High Speed, Plus Mode
		X	High Speed, X-Mode

**2a) V430-F 0.3 MP Monochrome Autofocus Camera (50 - 300 mm): Valid Combinations**
**V430-F000[Y]03M-[L][C][P]**

Key	Classification	Code	Meaning
Y	Lens	W	Wide Field of View - 5.2 mm Focal Length Lens
		M	Medium Field of View – 7.7 mm Focal Length Lens
L	Light Type	N	No Outer Light
		S	Standard Outer Light
C	Light Color	N	No Outer Light
		R	Red
		W	White
P	Software License	P	High Speed, Plus Mode
		X	High Speed, X-Mode

**2b) V430-F 1.2 MP Monochrome Autofocus Camera (50 - 300 mm for Wide and Medium, 40 – 150 mm for Narrow): Valid Combinations**
**V430-F000[Y]12M-[L][C][P]**

Key	Classification	Code	Meaning
Y	Lens	W	Wide Field of View - 5.2 mm Focal Length Lens
		M	Medium Field of View – 7.7 mm Focal Length Lens
		N	Narrow Field of View – 16 mm Focal Length Lens
L	Light Type	N	No Outer Light
		S	Standard Outer Light
C	Light Color	N	No Outer Light
		R	Red
		W	White
P	Software License	P	High Speed, Plus Mode
		X	High Speed, X-Mode

**2c) V430-F 5.0 MP Color Autofocus Camera (50 - 300 mm): Valid Combinations**

**Note:** Narrow Autofocus lens option not available for color camera.

**V430-F000[Y]50C-[L][C][P]**

Key	Classification	Code	Meaning
Y	Lens	W	Wide Field of View - 5.2 mm Focal Length Lens
		M	Medium Field of View – 7.7 mm Focal Length Lens
L	Light Type	N	No Outer Light
		S	Standard Outer Light
C	Light Color	N	No Outer Light
		W	White
P	Software License	P	High Speed, Plus Mode
		X	High Speed, X-Mode

## 2d) V430-F 1.2 MP Monochrome Autofocus Camera with Ring Light (50 - 300 mm for Medium, 40 – 150 mm for Narrow): Valid Combinations

**Note:** Ring Light version is available for Autofocus, Medium, and Narrow lens, 1.2 MP Monochrome camera only.

### V430-F000[Y]12M-R[C]X

Key	Classification	Code	Meaning
Y	Lens	M	Medium Field of View – 7.7 mm Focal Length Lens
		N	Narrow Field of View – 16 mm Focal Length Lens
C	Light Color	R	Red
		W	White

## 2e) V430-F 1.2 MP Monochrome Long Range Autofocus Camera (75 - 1160 mm): Valid Combinations

**Note:** Autofocus Long Range lens option available for 1.2 MP Monochrome camera only.

### V430-F000L12M-[L][C][P]

Key	Classification	Code	Meaning
L	Light Type	N	No Outer Light
		S	Standard Outer Light
C	Light Color	N	No Outer Light
		R	Red
		W	White
P	Software License	P	High Speed, Plus Mode
		X	High Speed, X-Mode



Zapraszamy do kontaktu!  
Więcej informacji: [www.kreski.pl](http://www.kreski.pl)

## Field of View Charts

Specifications are subject to change.

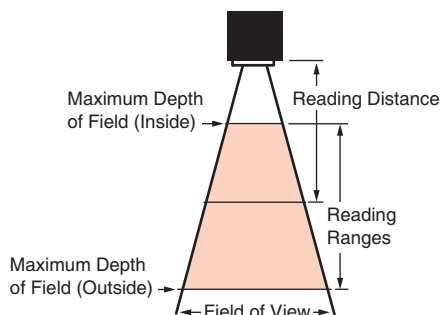

### Fixed Focus Field of View (mm) - Wide Lens

Distance (mm)	0.3 MP		1.2 MP		5 MP	
	Width	Height	Width	Height	Width	Height
50	49	32	53	39	50	38
64	62	39	66	49	63	47
81	76	49	81	61	78	58
102	95	60	101	75	96	72
133	121	78	129	97	124	92
190	171	109	182	136	174	130
300	266	170	283	213	271	202

### Fixed Focus Field of View (mm) - Medium Lens

Distance (mm)	0.3 MP		1.2 MP		5 MP	
	Width	Height	Width	Height	Width	Height
50	34	22	36	27	35	26
64	43	27	45	34	43	32
81	53	34	56	42	54	40
102	66	42	70	52	67	50
133	84	54	90	67	86	64
190	119	76	126	95	121	90
300	185	118	196	147	188	140

### Fixed Focus Field of View (mm) - Narrow Lens

Distance (mm)	1.2 MP	
	Width	Height
64	21	15
400	118	88



Zapraszamy do kontaktu!  
Więcej informacji: [www.kreski.pl](http://www.kreski.pl)

### Autofocus Field of View (mm) - Wide Lens

Distance (mm)	0.3 MP		1.2 MP		5 MP	
	Width	Height	Width	Height	Width	Height
50	51	33	55	41	52	39
100	97	62	103	77	98	73
150	142	90	151	113	144	107
200	187	119	199	149	190	142
250	232	148	247	185	236	176
300	277	177	295	221	282	210

### Autofocus Field of View (mm) - Medium Lens

Distance (mm)	0.3 MP		1.2 MP		5 MP	
	Width	Height	Width	Height	Width	Height
50	33	21	36	27	34	25
100	63	40	67	50	64	48
150	92	59	98	73	94	70
200	121	77	129	97	123	92
250	151	96	160	120	153	114
300	180	115	191	144	183	136

### Autofocus Field of View (mm) - Narrow Lens

Distance (mm)	1.2 MP	
	Width	Height
50	16	12
100	31	23
150	45	34

### Long Range Autofocus Field of View (mm)

Distance (mm)	1.2 MP	
	Width	Height
75	24	18
100	31	23
200	60	45
300	89	67
400	118	88
500	147	110
600	176	132
700	204	153
800	233	175
900	262	197
1000	291	218
1200	349	262
1300	378	283
1400	407	305
1500	436	327



Zapraszamy do kontaktu!  
Więcej informacji: [www.kreski.pl](http://www.kreski.pl)

## Readability Tables

---

The readability tables on the following pages are designed to help users choose the best read-distance, sensor, and lens combination to read their particular code size and code type successfully.

The readability tables show the calculated PPE (pixels per element) for a range of typical code sizes at all the MicroHAWK Fixed Focus distances with the Wide, Medium, Narrow, and Long Range lens as well as with the 0.3MP, 1.2MP, and 5MP sensors.

PPE is defined as the following for 1D and 2D codes:

- PPE for 1D codes is the number of pixels across the thinnest bar in the barcode.
- PPE for 2D codes is the number of pixels across a single code cell.

The tables show a color code for readability based on Direct Part Marks (DPM) where red means not likely to read, and green means that it should read. The tables also show a range of colors between red and green, while showing the zone where read rates may be acceptable for high-contrast, well-printed labels and can be considered. See the 1D and 2D Code Readability Guidelines below for Minimum and Preferred PPE for both DPM marks and high-contrast labels.



### 1D Code Readability Guidelines

---

#### High-Contrast Labels

- 1.5 pixels per thin bar is suggested minimum;
- 2 pixels or more per thin bar is preferred.

#### Direct Part Marks

- 2 pixels per thin bar is suggested minimum;
- 2.5 pixels or more per thin bar is preferred.

### 2D Code Readability Guidelines

---

#### High-Contrast Labels

- 2.5 – 2.75 pixels per 2D cell is suggested minimum;
- 3.5 – 5 pixels per 2D cell is preferred.

#### Direct Part Marks

- 3.25 pixels per 2D Cell is suggested minimum;
- 4 – 6 pixels per 2D Cell is preferred.



Zapraszamy do kontaktu!  
Więcej informacji: [www.kreski.pl](http://www.kreski.pl)

## Readability Table – 0.3 Megapixel

= Maximum Readability  
 = Minimum Readability

0.3 Megapixel – Pixels Per Element / Readability Chart																		
Minimum Element Size	Readability of 1D Code at Distance (mm)								Lens	Readability of 2D Code at Distance (mm)								
	50	64	81	102	133	190	300	400		50	64	81	102	133	190	300	400	
2 mil	0.7	0.6	0.5	0.4	0.3	0.2	0.1	0.1	Wide Lens	0.7	0.6	0.5	0.4	0.3	0.2	0.1	0.1	
2.5 mil	0.9	0.7	0.6	0.5	0.4	0.3	0.2	0.1		0.9	0.7	0.6	0.5	0.4	0.3	0.2	0.1	0.1
3.3 mil	1.2	1.0	0.8	0.6	0.5	0.4	0.2	0.2		1.2	1.0	0.8	0.6	0.5	0.4	0.2	0.2	0.2
5 mil	1.9	1.5	1.2	1.0	0.8	0.5	0.3	0.3		1.9	1.5	1.2	1.0	0.8	0.5	0.3	0.3	0.3
7.5 mil	2.8	2.2	1.8	1.5	1.1	0.8	0.5	0.4		2.8	2.2	1.8	1.5	1.1	0.8	0.5	0.4	0.4
10 mil	3.7	3.0	2.4	1.9	1.5	1.1	0.7	0.5		3.7	3.0	2.4	1.9	1.5	1.1	0.7	0.5	0.5
15 mil	5.6	4.5	3.6	2.9	2.3	1.6	1.0	0.8		5.6	4.5	3.6	2.9	2.3	1.6	1.0	0.8	0.8
20 mil	7.4	6.0	4.8	3.9	3.0	2.1	1.4	1.0		7.4	6.0	4.8	3.9	3.0	2.1	1.4	1.0	1.0
30 mil	11.1	8.9	7.2	5.8	4.5	3.2	2.1	1.6		11.1	8.9	7.2	5.8	4.5	3.2	2.1	1.6	1.6
40 mil	14.9	11.9	9.6	7.8	6.0	4.3	2.8	2.1		14.9	11.9	9.6	7.8	6.0	4.3	2.8	2.1	2.1

2 mil	1.2	1.0	0.8	0.6	0.5	0.3	0.2	0.2	Medium Lens	1.2	1.0	0.8	0.6	0.5	0.3	0.2	0.2	
2.5 mil	1.5	1.2	1.0	0.8	0.6	0.4	0.3	0.2		1.5	1.2	1.0	0.8	0.6	0.4	0.3	0.2	0.2
3.3 mil	2.0	1.6	1.3	1.0	0.8	0.6	0.4	0.3		2.0	1.6	1.3	1.0	0.8	0.6	0.4	0.3	0.3
5 mil	3.0	2.4	1.9	1.6	1.2	0.9	0.6	0.4		3.0	2.4	1.9	1.6	1.2	0.9	0.6	0.4	0.4
7.5 mil	4.5	3.6	2.9	2.3	1.8	1.3	0.8	0.6		4.5	3.6	2.9	2.3	1.8	1.3	0.8	0.6	0.6
10 mil	5.9	4.8	3.8	3.1	2.4	1.7	1.1	0.8		5.9	4.8	3.8	3.1	2.4	1.7	1.1	0.8	0.8
15 mil	8.9	7.2	5.8	4.7	3.6	2.6	1.7	1.2		8.9	7.2	5.8	4.7	3.6	2.6	1.7	1.2	1.2
20 mil	11.9	9.5	7.7	6.2	4.8	3.4	2.2	1.7		11.9	9.5	7.7	6.2	4.8	3.4	2.2	1.7	1.7
30 mil	17.8	14.3	11.5	9.3	7.3	5.2	3.3	2.5		17.8	14.3	11.5	9.3	7.3	5.2	3.3	2.5	2.5
40 mil	23.8	19.1	15.4	12.4	9.7	6.9	4.4	3.3		23.8	19.1	15.4	12.4	9.7	6.9	4.4	3.3	3.3

2 mil	2.5	2.0	1.6	1.3	1.0	0.7	0.5	0.3	Narrow Lens	2.5	2.0	1.6	1.3	1.0	0.7	0.5	0.3	
2.5 mil	3.1	2.5	2.0	1.6	1.3	0.9	0.6	0.4		3.1	2.5	2.0	1.6	1.3	0.9	0.6	0.4	0.4
3.3 mil	4.1	3.3	2.6	2.1	1.7	1.2	0.8	0.6		4.1	3.3	2.6	2.1	1.7	1.2	0.8	0.6	0.6
5 mil	6.2	4.9	4.0	3.2	2.5	1.8	1.1	0.9		6.2	4.9	4.0	3.2	2.5	1.8	1.1	0.9	0.9
7.5 mil	9.2	7.4	6.0	4.8	3.8	2.7	1.7	1.3		9.2	7.4	6.0	4.8	3.8	2.7	1.7	1.3	1.3
10 mil	12.3	9.9	8.0	6.4	5.0	3.6	2.3	1.7		12.3	9.9	8.0	6.4	5.0	3.6	2.3	1.7	1.7
15 mil	18.5	14.8	12.0	9.7	7.5	5.4	3.4	2.6		18.5	14.8	12.0	9.7	7.5	5.4	3.4	2.6	2.6
20 mil	24.7	19.8	16.0	12.9	10.0	7.1	4.6	3.5		24.7	19.8	16.0	12.9	10.0	7.1	4.6	3.5	3.5
30 mil	37.0	29.7	24.0	19.3	15.1	10.7	6.9	5.2		37.0	29.7	24.0	19.3	15.1	10.7	6.9	5.2	5.2
40 mil	49.3	39.6	31.9	25.8	20.1	14.3	9.2	6.9		49.3	39.6	31.9	25.8	20.1	14.3	9.2	6.9	6.9



Zapraszamy do kontaktu!  
 Więcej informacji: [www.kreski.pl](http://www.kreski.pl)

# Readability Table – 1.2 Megapixel

1.2 Megapixel – Pixels Per Element / Readability Chart																	
Minimum Element Size	Readability of 1D Code at Distance (mm)								Lens	Readability of 2D Code at Distance (mm)							
	50	64	81	102	133	190	300	400		50	64	81	102	133	190	300	400
<b>2 mil</b>	1.2	1.0	0.8	0.6	0.5	0.4	0.2	0.2	Wide Lens	1.2	1.0	0.8	0.6	0.5	0.4	0.2	0.2
<b>2.5 mil</b>	1.5	1.2	1.0	0.8	0.6	0.4	0.3	0.2		1.5	1.2	1.0	0.8	0.6	0.4	0.3	0.2
<b>3.3 mil</b>	2.0	1.6	1.3	1.1	0.8	0.6	0.4	0.3		2.0	1.6	1.3	1.1	0.8	0.6	0.4	0.3
<b>5 mil</b>	3.1	2.5	2.0	1.6	1.3	0.9	0.6	0.4		3.1	2.5	2.0	1.6	1.3	0.9	0.6	0.4
<b>7.5 mil</b>	4.6	3.7	3.0	2.4	1.9	1.3	0.9	0.6		4.6	3.7	3.0	2.4	1.9	1.3	0.9	0.6
<b>10 mil</b>	6.2	5.0	4.0	3.2	2.5	1.8	1.1	0.9		6.2	5.0	4.0	3.2	2.5	1.8	1.1	0.9
<b>15 mil</b>	9.3	7.4	6.0	4.8	3.8	2.7	1.7	1.3		9.3	7.4	6.0	4.8	3.8	2.7	1.7	1.3
<b>20 mil</b>	12.4	9.9	8.0	6.5	5.0	3.6	2.3	1.7		12.4	9.9	8.0	6.5	5.0	3.6	2.3	1.7
<b>30 mil</b>	18.5	14.9	12.0	9.7	7.5	5.4	3.4	2.6		18.5	14.9	12.0	9.7	7.5	5.4	3.4	2.6
<b>40 mil</b>	24.7	19.8	16.0	12.9	10.1	7.2	4.6	3.5		24.7	19.8	16.0	12.9	10.1	7.2	4.6	3.5
<b>2 mil</b>	1.8	1.4	1.2	0.9	0.7	0.5	0.3	0.2	Medium Lens	1.8	1.4	1.2	0.9	0.7	0.5	0.3	0.2
<b>2.5 mil</b>	2.2	1.8	1.4	1.2	0.9	0.6	0.4	0.3		2.2	1.8	1.4	1.2	0.9	0.6	0.4	0.3
<b>3.3 mil</b>	2.9	2.4	1.9	1.5	1.2	0.9	0.5	0.4		2.9	2.4	1.9	1.5	1.2	0.9	0.5	0.4
<b>5 mil</b>	4.5	3.6	2.9	2.3	1.8	1.3	0.8	0.6		4.5	3.6	2.9	2.3	1.8	1.3	0.8	0.6
<b>7.5 mil</b>	6.7	5.4	4.3	3.5	2.7	1.9	1.2	0.9		6.7	5.4	4.3	3.5	2.7	1.9	1.2	0.9
<b>10 mil</b>	8.9	7.2	5.8	4.7	3.6	2.6	1.7	1.2		8.9	7.2	5.8	4.7	3.6	2.6	1.7	1.2
<b>15 mil</b>	13.4	10.7	8.7	7.0	5.4	3.9	2.5	1.9		13.4	10.7	8.7	7.0	5.4	3.9	2.5	1.9
<b>20 mil</b>	17.8	14.3	11.5	9.3	7.3	5.2	3.3	2.5		17.8	14.3	11.5	9.3	7.3	5.2	3.3	2.5
<b>30 mil</b>	26.7	21.5	17.3	14.0	10.9	7.7	5.0	3.7		26.7	21.5	17.3	14.0	10.9	7.7	5.0	3.7
<b>40 mil</b>	35.6	28.6	23.1	18.6	14.5	10.3	6.6	5.0		35.6	28.6	23.1	18.6	14.5	10.3	6.6	5.0
<b>2 mil</b>	3.9	3.2	2.6	2.1	1.6	1.1	0.7	0.6	Narrow Lens	3.9	3.2	2.6	2.1	1.6	1.1	0.7	0.6
<b>2.5 mil</b>	4.9	4.0	3.2	2.6	2.0	1.4	0.9	0.7		4.9	4.0	3.2	2.6	2.0	1.4	0.9	0.7
<b>3.3 mil</b>	6.5	5.2	4.2	3.4	2.7	1.9	1.2	0.9		6.5	5.2	4.2	3.4	2.7	1.9	1.2	0.9
<b>5 mil</b>	9.9	7.9	6.4	5.2	4.0	2.9	1.8	1.4		9.9	7.9	6.4	5.2	4.0	2.9	1.8	1.4
<b>7.5 mil</b>	14.8	11.9	9.6	7.7	6.0	4.3	2.7	2.1		14.8	11.9	9.6	7.7	6.0	4.3	2.7	2.1
<b>10 mil</b>	19.7	15.8	12.8	10.3	8.0	5.7	3.7	2.8		19.7	15.8	12.8	10.3	8.0	5.7	3.7	2.8
<b>15 mil</b>	29.6	23.8	19.2	15.5	12.0	8.6	5.5	4.1		29.6	23.8	19.2	15.5	12.0	8.6	5.5	4.1
<b>20 mil</b>	39.5	31.7	25.6	20.6	16.1	11.4	7.3	5.5		39.5	31.7	25.6	20.6	16.1	11.4	7.3	5.5
<b>30 mil</b>	59.2	47.5	38.3	30.9	24.1	17.1	11.0	8.3		59.2	47.5	38.3	30.9	24.1	17.1	11.0	8.3
<b>40 mil</b>	78.9	63.3	51.1	41.3	32.1	22.8	14.6	11.1		78.9	63.3	51.1	41.3	32.1	22.8	14.6	11.1



Zapraszamy do kontaktu!  
Więcej informacji: [www.kreski.pl](http://www.kreski.pl)

## Readability Table – 5 Megapixel

5 Megapixel – Pixels Per Element / Readability Chart																	
Minimum Element Size	Readability of 1D Code at Distance (mm)								Lens	Readability of 2D Code at Distance (mm)							
	50	64	81	102	133	190	300	400		50	64	81	102	133	190	300	400
2 mil	1.7	1.4	1.1	0.9	0.7	0.5	0.3	0.2	Wide Lens	1.7	1.4	1.1	0.9	0.7	0.5	0.3	0.2
2.5 mil	2.2	1.7	1.4	1.1	0.9	0.6	0.4	0.3		2.2	1.7	1.4	1.1	0.9	0.6	0.4	0.3
3.3 mil	2.8	2.3	1.8	1.5	1.2	0.8	0.5	0.4		2.8	2.3	1.8	1.5	1.2	0.8	0.5	0.4
5 mil	4.3	3.5	2.8	2.3	1.8	1.2	0.8	0.6		4.3	3.5	2.8	2.3	1.8	1.2	0.8	0.6
7.5 mil	6.5	5.2	4.2	3.4	2.6	1.9	1.2	0.9		6.5	5.2	4.2	3.4	2.6	1.9	1.2	0.9
10 mil	8.6	6.9	5.6	4.5	3.5	2.5	1.6	1.2		8.6	6.9	5.6	4.5	3.5	2.5	1.6	1.2
15 mil	12.9	10.4	8.4	6.8	5.3	3.7	2.4	1.8		12.9	10.4	8.4	6.8	5.3	3.7	2.4	1.8
20 mil	17.3	13.9	11.2	9.0	7.0	5.0	3.2	2.4		17.3	13.9	11.2	9.0	7.0	5.0	3.2	2.4
30 mil	25.9	20.8	16.8	13.5	10.5	7.5	4.8	3.6		25.9	20.8	16.8	13.5	10.5	7.5	4.8	3.6
40 mil	34.5	27.7	22.4	18.1	14.1	10.0	6.4	4.8		34.5	27.7	22.4	18.1	14.1	10.0	6.4	4.8
2 mil	2.5	2.0	1.6	1.3	1.0	0.7	0.5	0.3	Medium Lens	2.5	2.0	1.6	1.3	1.0	0.7	0.5	0.3
2.5 mil	3.1	2.5	2.0	1.6	1.3	0.9	0.6	0.4		3.1	2.5	2.0	1.6	1.3	0.9	0.6	0.4
3.3 mil	4.1	3.3	2.7	2.1	1.7	1.2	0.8	0.6		4.1	3.3	2.7	2.1	1.7	1.2	0.8	0.6
5 mil	6.2	5.0	4.0	3.3	2.5	1.8	1.2	0.9		6.2	5.0	4.0	3.3	2.5	1.8	1.2	0.9
7.5 mil	9.3	7.5	6.0	4.9	3.8	2.7	1.7	1.3		9.3	7.5	6.0	4.9	3.8	2.7	1.7	1.3
10 mil	12.5	10.0	8.1	6.5	5.1	3.6	2.3	1.7		12.5	10.0	8.1	6.5	5.1	3.6	2.3	1.7
15 mil	18.7	15.0	12.1	9.8	7.6	5.4	3.5	2.6		18.7	15.0	12.1	9.8	7.6	5.4	3.5	2.6
20 mil	24.9	20.0	16.1	13.0	10.1	7.2	4.6	3.5		24.9	20.0	16.1	13.0	10.1	7.2	4.6	3.5
30 mil	37.4	30.0	24.2	19.5	15.2	10.8	6.9	5.2		37.4	30.0	24.2	19.5	15.2	10.8	6.9	5.2
40 mil	49.8	40.0	32.3	26.0	20.3	14.4	9.2	7.0		49.8	40.0	32.3	26.0	20.3	14.4	9.2	7.0
2 mil	5.5	4.4	3.6	2.9	2.2	1.6	1.0	0.8	Narrow Lens	5.5	4.4	3.6	2.9	2.2	1.6	1.0	0.8
2.5 mil	6.9	5.5	4.5	3.6	2.8	2.0	1.3	1.0		6.9	5.5	4.5	3.6	2.8	2.0	1.3	1.0
3.3 mil	9.1	7.3	5.9	4.8	3.7	2.6	1.7	1.3		9.1	7.3	5.9	4.8	3.7	2.6	1.7	1.3
5 mil	13.8	11.1	8.9	7.2	5.6	4.0	2.6	1.9		13.8	11.1	8.9	7.2	5.6	4.0	2.6	1.9
7.5 mil	20.7	16.6	13.4	10.8	8.4	6.0	3.8	2.9		20.7	16.6	13.4	10.8	8.4	6.0	3.8	2.9
10 mil	27.6	22.1	17.8	14.4	11.2	8.0	5.1	3.9		27.6	22.1	17.8	14.4	11.2	8.0	5.1	3.9
15 mil	41.3	33.2	26.8	21.6	16.8	12.0	7.7	5.8		41.3	33.2	26.8	21.6	16.8	12.0	7.7	5.8
20 mil	55.1	44.2	35.7	28.8	22.4	15.9	10.2	7.7		55.1	44.2	35.7	28.8	22.4	15.9	10.2	7.7
30 mil	82.7	66.4	53.5	43.2	33.7	23.9	15.3	11.6		82.7	66.4	53.5	43.2	33.7	23.9	15.3	11.6
40 mil	110.2	88.5	71.4	57.6	44.9	31.9	20.5	15.4		110.2	88.5	71.4	57.6	44.9	31.9	20.5	15.4



Zapraszamy do kontaktu!  
Więcej informacji: [www.kreski.pl](http://www.kreski.pl)



## Readability Table – Long Range

Long Range readability is shown out to 1,500 even though Autofocus is only specified out to 1,160. At the longest focus distance, the lens has a very deep depth of field. Large codes can actually be read beyond 2,000 mm.

Long Range 1.2 MP - Pixels Per Element/Readability Chart															
Readability of 1D Code at Distance (mm)															
Min Element Size	100	200	300	400	500	600	700	800	900	1000	1100	1200	1300	1400	1500
2 mil	2.10	1.09	0.73	0.55	0.44	0.37	0.32	0.28	0.25	0.22	0.20	0.19	0.17	0.16	0.15
2.5 mil	2.63	1.36	0.92	0.69	0.55	0.46	0.40	0.35	0.31	0.28	0.25	0.23	0.22	0.20	0.19
3.3 mil	3.47	1.79	1.21	0.91	0.73	0.61	0.52	0.46	0.41	0.37	0.34	0.31	0.28	0.26	0.25
5 mil	5.25	2.72	1.83	1.38	1.11	0.93	0.80	0.70	0.62	0.56	0.51	0.47	0.43	0.40	0.37
7.5 mil	7.88	4.07	2.75	2.07	1.66	1.39	1.19	1.04	0.93	0.84	0.76	0.70	0.65	0.60	0.56
10 mil	10.51	5.43	3.66	2.76	2.22	1.85	1.59	1.39	1.24	1.12	1.02	0.93	0.86	0.80	0.75
15 mil	15.76	8.15	5.49	4.14	3.33	2.78	2.39	2.09	1.86	1.67	1.52	1.40	1.29	1.20	1.12
20 mil	21.02	10.86	7.32	5.53	4.44	3.70	3.18	2.79	2.48	2.23	2.03	1.86	1.72	1.60	1.49
30 mil	31.52	16.30	10.99	8.29	6.65	5.56	4.77	4.18	3.72	3.35	3.05	2.79	2.58	2.40	2.24
40 mil	42.03	21.73	14.65	11.05	8.87	7.41	6.36	5.57	4.96	4.47	4.06	3.73	3.44	3.20	2.98

Readability of 2D Code at Distance (mm)															
Min Element Size	100	200	300	400	500	600	700	800	900	1000	1100	1200	1300	1400	1500
2 mil	2.10	1.09	0.73	0.55	0.44	0.37	0.32	0.28	0.25	0.22	0.20	0.19	0.17	0.16	0.15
2.5 mil	2.63	1.36	0.92	0.69	0.55	0.46	0.40	0.35	0.31	0.28	0.25	0.23	0.22	0.20	0.19
3.3 mil	3.47	1.79	1.21	0.91	0.73	0.61	0.52	0.46	0.41	0.37	0.34	0.31	0.28	0.26	0.25
5 mil	5.25	2.72	1.83	1.38	1.11	0.93	0.80	0.70	0.62	0.56	0.51	0.47	0.43	0.40	0.37
7.5 mil	7.88	4.07	2.75	2.07	1.66	1.39	1.19	1.04	0.93	0.84	0.76	0.70	0.65	0.60	0.56
10 mil	10.51	5.43	3.66	2.76	2.22	1.85	1.59	1.39	1.24	1.12	1.02	0.93	0.86	0.80	0.75
15 mil	15.76	8.15	5.49	4.14	3.33	2.78	2.39	2.09	1.86	1.67	1.52	1.40	1.29	1.20	1.12
20 mil	21.02	10.86	7.32	5.53	4.44	3.70	3.18	2.79	2.48	2.23	2.03	1.86	1.72	1.60	1.49
30 mil	31.52	16.30	10.99	8.29	6.65	5.56	4.77	4.18	3.72	3.35	3.05	2.79	2.58	2.40	2.24
40 mil	42.03	21.73	14.65	11.05	8.87	7.41	6.36	5.57	4.96	4.47	4.06	3.73	3.44	3.20	2.98



Zapraszamy do kontaktu!  
Więcej informacji: [www.kreski.pl](http://www.kreski.pl)

# Ratings and Specifications

V430-F		V430-F□□□□03M-□□□	V430-F□□□□12M-□□□	V430-F□□□□50C-□□□
Symbolologies *1	1D Symbolologies	Code 39, Code 128, BC412, Interleaved 2 of 5, UPC/EAN, Codabar, Code 93, Pharmacode, PLANET, Postnet, Japanese Post, Australian Post, Royal Mail, Intelligent Mail, KIX		
	2D Symbolologies	Data Matrix (ECC 0-200), QR Code, Micro QR Code, Aztec Code, DotCode		
	Stacked Symbolologies	PDF417, MicroPDF417, GS1 Databar (Composite and Stacked)		
Reading Performance *2	Number of Reading Digits	No Upper Limit (depending on bar width and reading distance)		
	Aiming Light	Two Blue LEDs		
	Illumination	Inner LEDs: Four White and Four Red (Wavelength: 625 nm)		
		Outer LEDs:	8 Red or White	Outer LEDs: 8 Red or White; 24 Red or White for V430-F□□□□12M-R□□
	Reading Distance / Field of View	Refer to <i>Field of View Charts</i> for details.		
	Pitch Angle (α) *3	±30°		
	Skew Angle (β) *3	±30°		
Tilt Angle (γ) *3	±180°			
Image Capture	Focus	Liquid Lens Autofocus or Fixed Focus (Wide = 5.2 mm, Medium = 7.7 mm, Narrow = 16 mm, L = 16 mm)		
	Resolution	752 (H) x 480 (V)	1280 (H) x 960 (V)	2592 (H) x 1944 (V)
	Color / Monochrome	Monochrome CMOS	Monochrome CMOS	Color CMOS
	Shutter	Global Shutter	Global Shutter	Rolling Shutter
	Frames per Second	60 fps	42 fps	5 fps
	Exposure	50 to 100,000 μs		
Image Logging	FTP			
Trigger	External Trigger (Edge or Level), Communication Trigger (Ethernet, RS-232C)			
I/O Specifications	Input Signals	Trigger Input; New Master: Bi-Directional, Optoisolated, 4.5-28 V rated (10 mA @ 28 VDC)		
	Output Signals	3 Signals : Bi-Directional, Optoisolated, 1-28V rated, (ICE < 100 mA at 24VDC, current limited by user)		
Communication	Connectivity	RS-232C, Ethernet TCP/IP, EtherNet/IP, PROFINET		
	Ethernet Specifications	100BASE-TX / 10BASE-T		
Indicator LEDs	PASS (Green), TRIG (Amber), MODE (Amber), LINK (Amber), FAIL (Red), PWR (Green)			
Power Supply Voltage	DC24V (Ambient Voltage Range: DC5~30V) *5			
Current Consumption	0.18 A at 24 VDC (max.)			
Environmental Immunity *4	Ambient Temperature Range	Operating: 0 to 45° C Storage: -50 to 75° C (No Icing or Condensation)		
	Ambient Humidity Range	Operating and Storage: 5% to 95% (Non-Condensing)		
	Ambient Atmosphere	No Corrosive Gases		
	Vibration Resistance (Destructive)	Sine Vibration: 10 Hz to 55 Hz, 0.35 mm displacement, 20 cycles/axis. Random Vibration: 20 Hz to 2000 Hz, 6.295 Grms, 30 min/axis		
	Shock Resistance (Destructive)	50G, 11 ms, sawtooth profile. 3X in each X, Y, Z axis		
	Degree of Protection	IEC 60529 IP65 and IP67		
Weight	Main Body Only	Approx. 68 g		
	Packaging Weight	Approx. 174 g (including packing)		
Dimensions	Main Body Dimensions	44.5 (W) x 44.5 (D) x 25.4 (H) mm		
	Packaging Dimensions	170 (W) x 117 (D) x 86 (H) mm		
Accessories	ReadMeFirst, CE Compliance Sheet			
LED Safety Standard	IEC 62471-1: 2006 Risk-Exempt Group			
Safety Standards	EN 55024:2010, EN 55032:2015 + AC:2016 FCC Part 15, Subpart B (Class B) UL60950-1 BIS, RCM, KC, EAC, BSMI			
Materials	Case	Aluminum Diecast, Alumite (Black)		
	Reading Window	Acrylic		
Software	WebLink			

\*1. These symbolologies are supported based on Omron's read capability validation standard. Omron recommends that validation be performed for each application.

\*2. Unless otherwise specified, reading performance is defined with center of field of view, angle R=∞.



\*4. In an electrically noisy environment, use only the V430-F in combination with a noise filter cable (V430-W□F-□M) to ensure proper operation.

\*5. UL certification rating is DC24V. Maximum ripple is 200 mV p-p.

Zapraszamy do kontaktu!  
Więcej informacji: [www.kreski.pl](http://www.kreski.pl)

**Dimensions**

**V430-F**

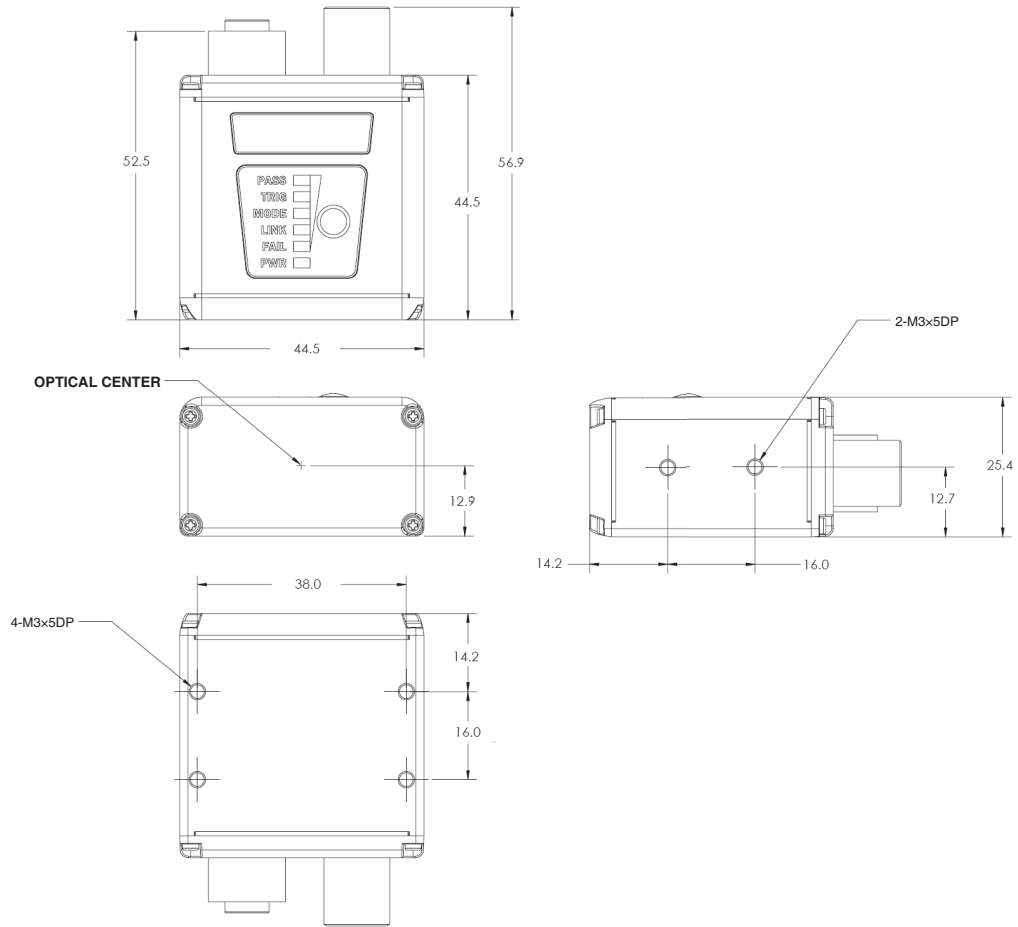

**V430-F with Alternate Optics and Illumination**

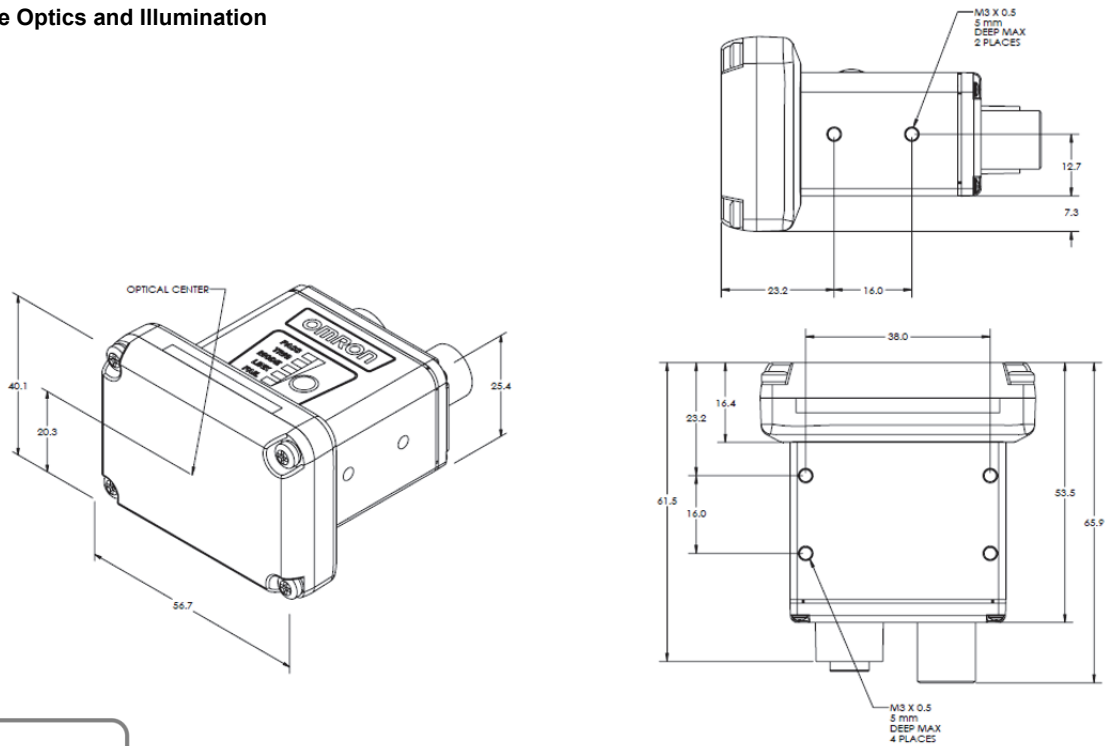

**Kreski**

Zapraszamy do kontaktu!  
Więcej informacji: [www.kreski.pl](http://www.kreski.pl)

L Bracket Adjustable Angle Mounting Kit  
V430-AM0

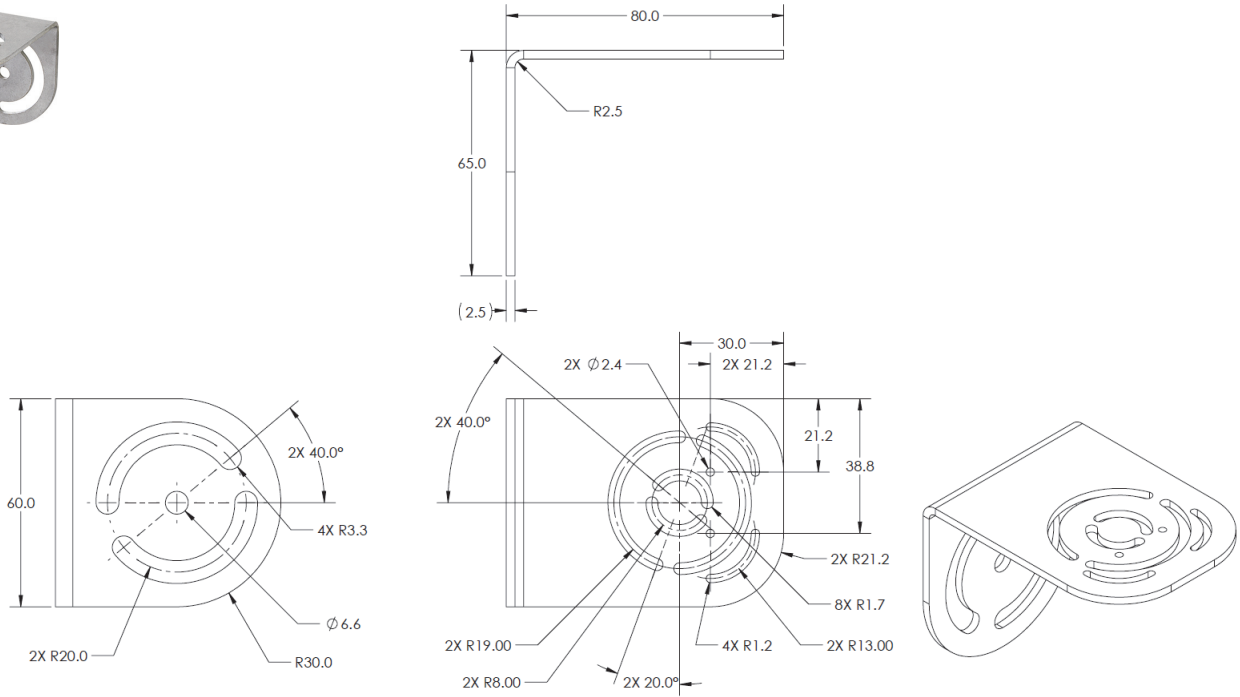

1/4-20 Camera Mounting Block Kit  
V430-AM1

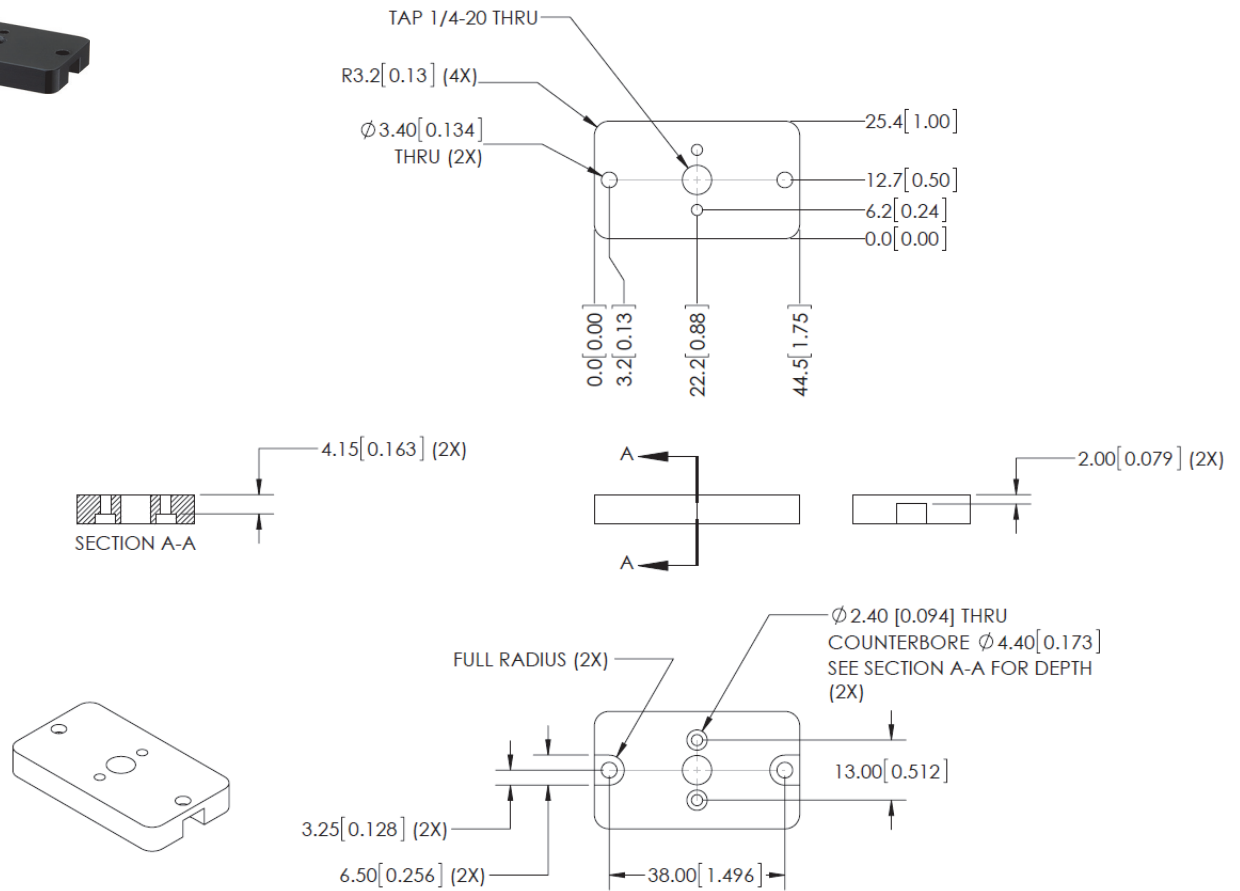

**4" (102 mm) Ram Mount Stand  
V430-AM2**

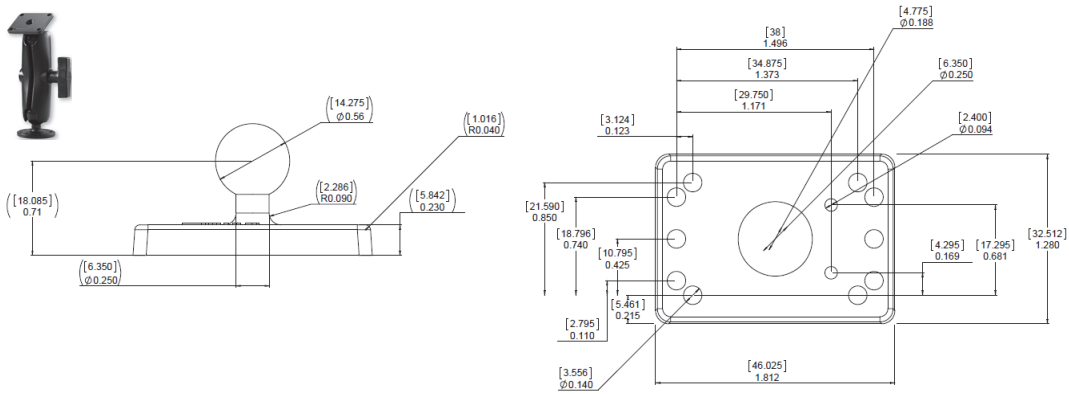

**APG Pan and Tilt Camera Mount  
V430-AM3**

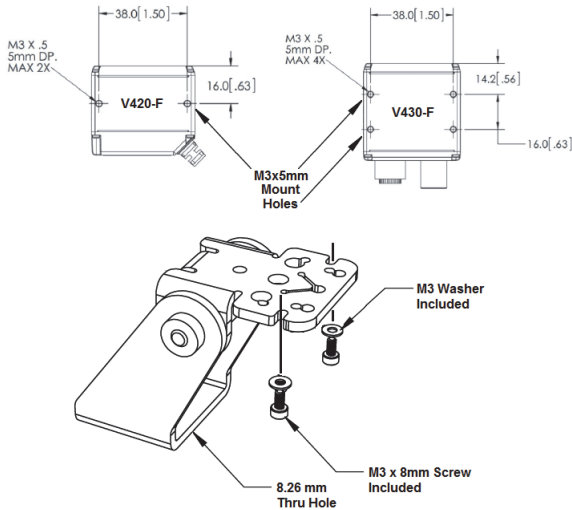

**Kreski**  
Zapraszamy do kontaktu!  
Więcej informacji: [www.kreski.pl](http://www.kreski.pl)

**MS-4 / MINI to V/F4XX-F Adapter Plate  
V430-AM5**

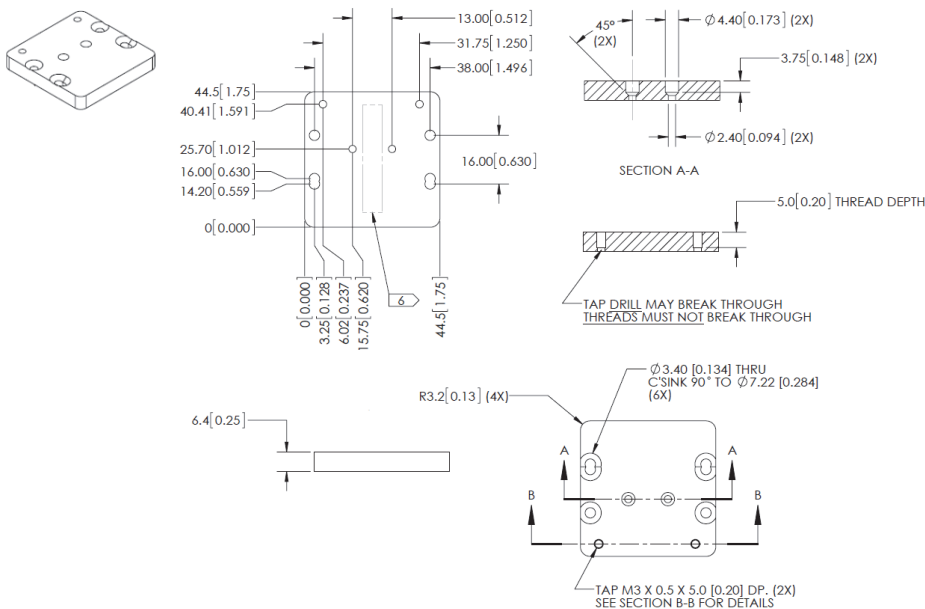

**Smart Ring Light to V/F4XX-F Mounting Bracket  
V430-AM6**

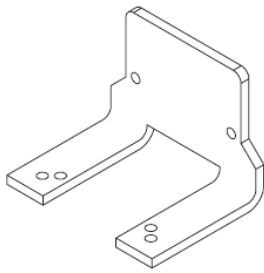
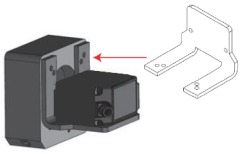

**Screws required:**

2 M3x6 mm screws to mount light to bracket

2 M3x6 mm screws to mount camera to bracket

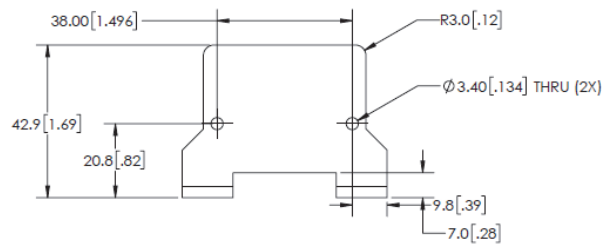
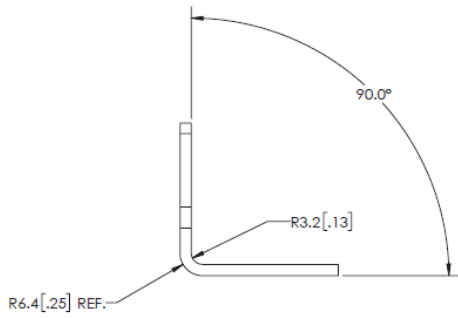
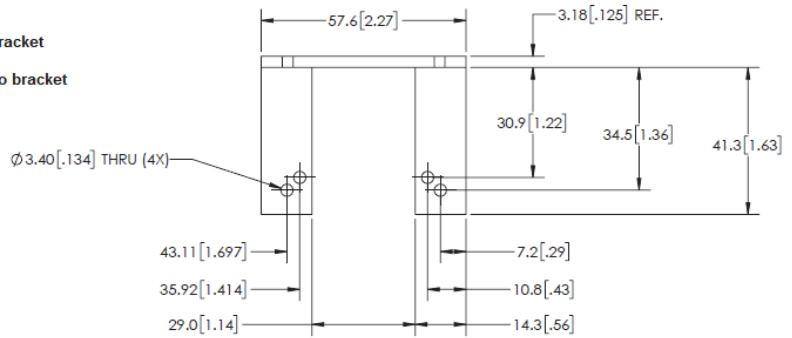
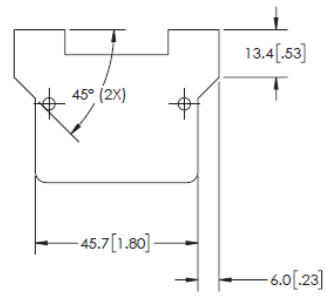

**QX / Vision HAWK to V/F4XX-F Adapter Plate  
V430-AM7**

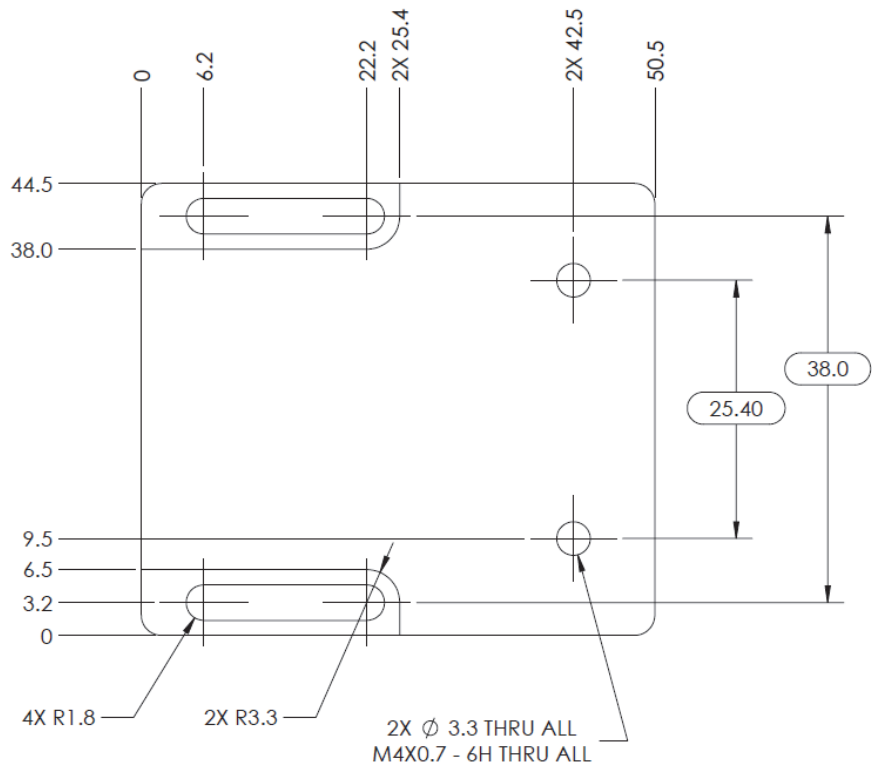
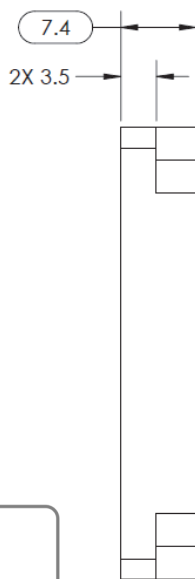
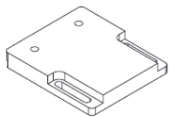

**Kreski**  
Zapraszamy do kontaktu!  
Więcej informacji: [www.kreski.pl](http://www.kreski.pl)

**Front Window Installation Kit  
V430-AF10 \***

**Diffuser Installation Kit  
V430-AF11 \***

**Polarizer Installation Kit  
V430-AF12 \***

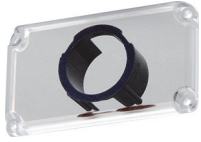



**Zapraszamy do kontaktu!  
Więcej informacji: [www.kreski.pl](http://www.kreski.pl)**

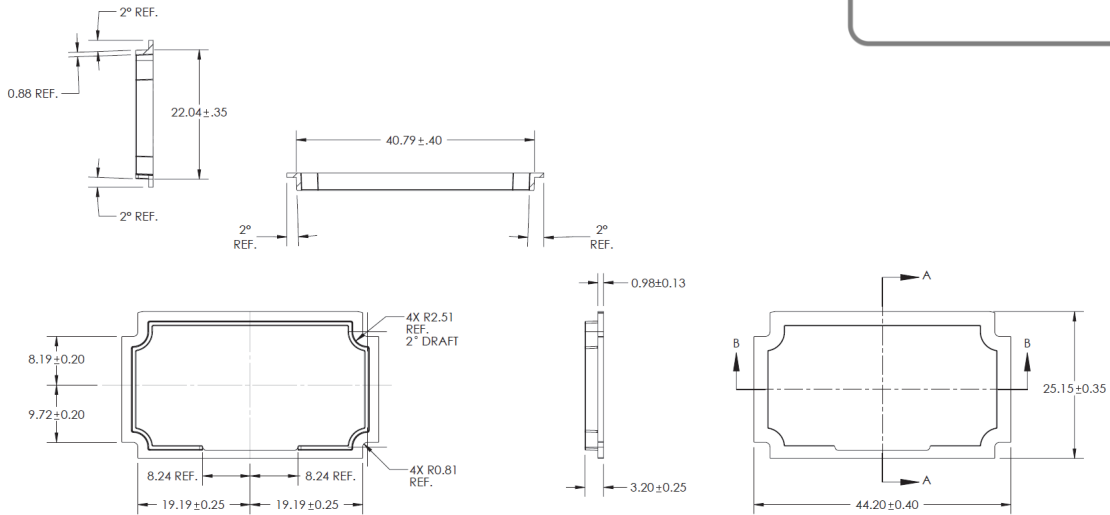

**\* Note:** V430-AF10, AF11, and AF12 are used for **MicroHAWK V/F4X0-FXXXXXXX-XXX** readers in this manual. The prior generation **MicroHAWK V430-FXXXXXXX** code reader uses part numbers V430-AF0, AF1, and AF2. Please select the correct accessory from the table based on your reader part number format.

Accessory	Prior V430-FXXXXXXX Code Reader	New V/F4X0-FXXXXXXX-XXX Code Reader and Smart Camera
Front Window Installation Kit	V430-AF0	V430-AF10
Diffuser Installation Kit	V430-AF1	V430-AF11
Polarizer Installation Kit	V430-AF2	V430-AF12

**Right Angle Mirror Installation Kit  
V430-AF3**

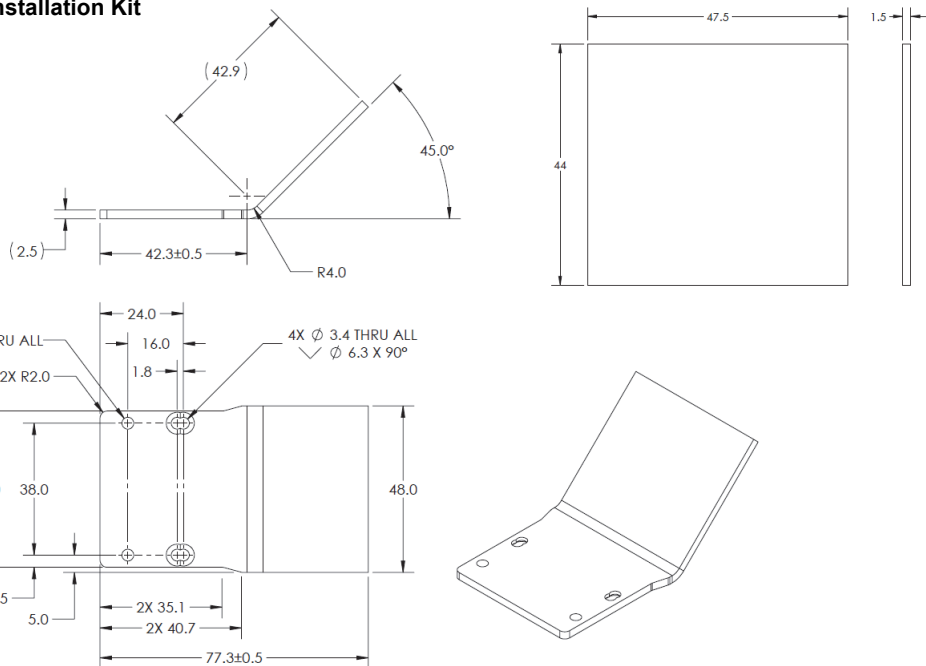
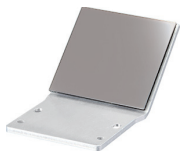

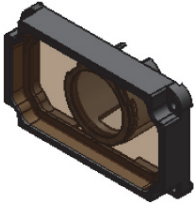
**YAG Laser Filter Window  
V430-AF4**

**Window Material**

Polymer

**Laser Type**

Argon  
Broadband  
KTP  
Nd:YAG

**Protection**

OD 6+ @ 200-532 nm  
OD 4+ @ 850-879 nm  
OD 5+ @ 900-1070 nm

The V430-AF4 YAG Laser Filter is used to block a range of wavelengths from a variety of laser types from being seen by the MicroHAWK camera that will either disrupt the camera's view of the object, or damage the MicroHAWK sensor.

The table shows the laser types that are handled by the V430-AF4 Filter window, as well as the level of protection they provide at the various wavelengths.

**Note:** Optical Density (OD) is a measure of the attenuation of energy passing through a filter. The higher the OD value, the higher the attenuation and the greater the protection level.

OD 4 blocks 99.99% of the laser energy.

OD 5 blocks 99.999% of the laser energy (YAG).

OD 6 blocks 99.9999% of the laser energy (Argon, KTP)

**ESD-Safe Window  
V430-AF5**

An ESD event occurs when an electrostatic charge rapidly transfers between two objects. This transfer is usually caused when two objects with a notable potential difference in electrical charge contact each other. However, ESD events can also happen when two objects close to one another create a highly charged electrostatic field.

ESD safety precautions are extremely important in the electronics and semiconductor industries where sensitive components can be damaged even by a discharge of a mere 20 volts. Less sensitive components may still be susceptible, and cumulative discharges can create long-term problems affecting the functionality and performance of electronic components.

The MicroHAWK V430-AF5 ESD-Safe window is designed with an ESD coating on the exterior surface to prevent static discharge between the reader or smart camera when the camera is deployed close to the component surface. The antistatic coating offers a resistivity of  $\leq 1.0 \times 10^9 \Omega/\text{sq}$  to prevent these electrostatic discharges.



Zapraszamy do kontaktu!  
Więcej informacji: [www.kreski.pl](http://www.kreski.pl)



**Red Filter Installation Kit  
V430-AF6**

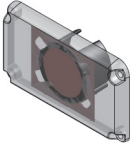

**Blue Filter Installation Kit  
V430-AF7**

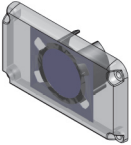

**Red Filter (V430-AF6) and Blue Filter (V430-AF7)**

The Red Filter (V430-AF6), and Blue Filter (V430-AF7) are used to turn MicroHAWKs equipped with white lights into units that emit red or blue light. MicroHAWK light color changes can be also be accomplished using the V430-F Red, Blue, White, or IR LED kits.

A typical example of how to use different color filters or LEDs with monochrome readers is shown below. The emitted color is matched with the color of the part that needs to be emphasized or de-emphasized, which creates sufficient contrast for the part to be inspected or for the symbol to be decoded. In the example below, the red filter makes the reddish copper look bright, while the green circuit board looks dark. The blue filter produces the opposite effect.

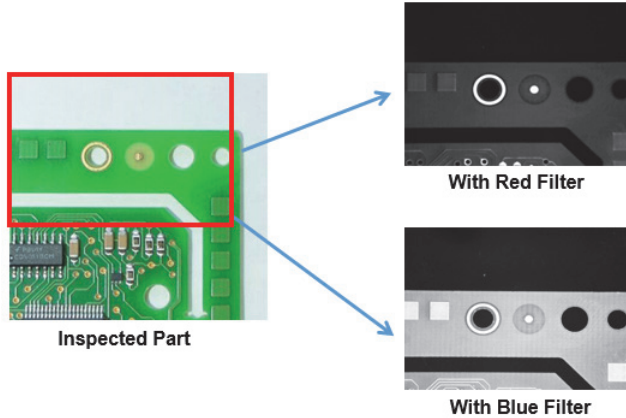

**Red Light Installation Kit  
V430-ALR**

**White Light Installation Kit  
V430-ALW**

**Blue Light Installation Kit  
V430-ALB**

**IR Light Installation Kit  
V430-ALI**

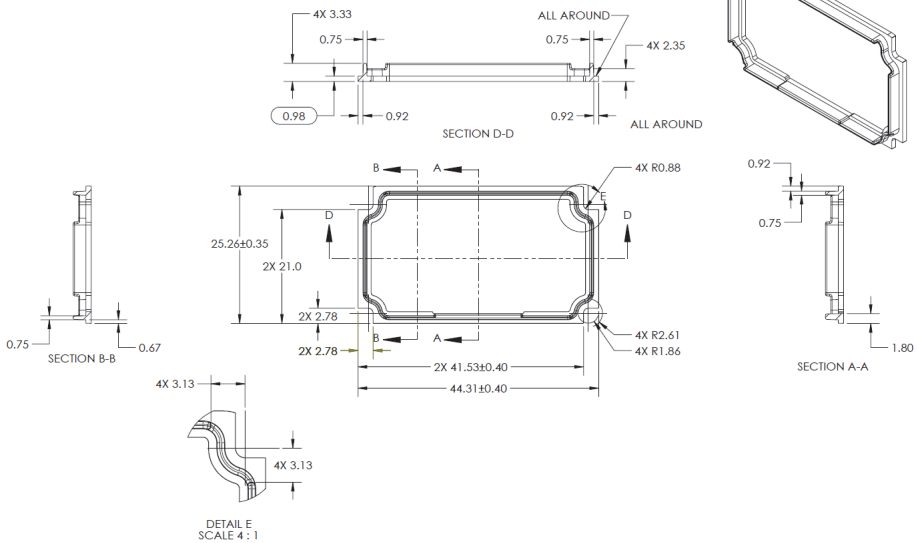
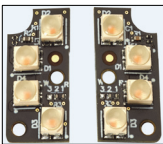

**QX-1 Interconnect Module – Power, Trigger, Smart Light Control Breakout  
98-000103-02**

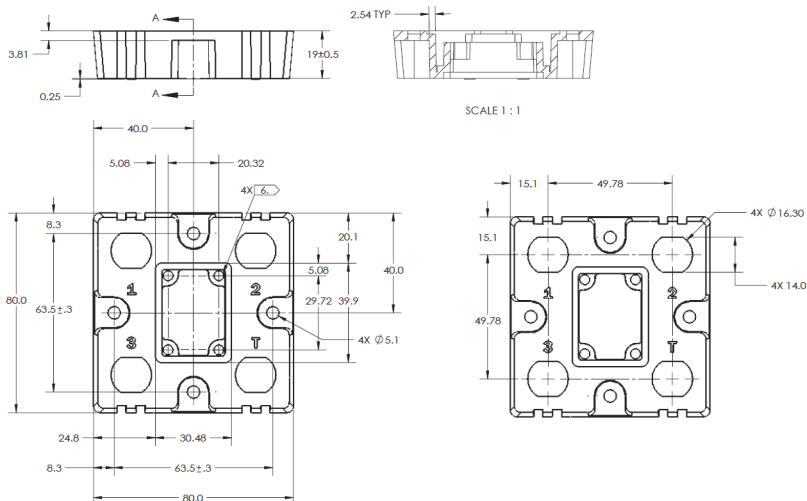

**Kreski**  
Zapraszamy do kontaktu!  
Więcej informacji: [www.kreski.pl](http://www.kreski.pl)

**QX-1 Photo Sensor, M12 4-Pin Plug, NPN – 2 Meters – Light ON / Dark ON**  
**99-9000016-01**

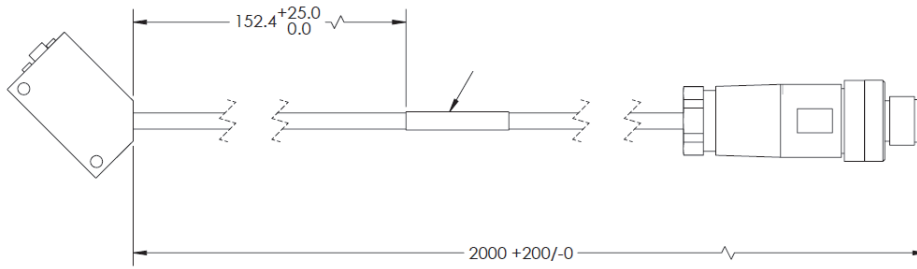

**QX-1 Field-Wireable M12 4-Pin Plug for Any Trigger Source or Photo Sensor – Screw Terminals**  
**98-9000239-01**

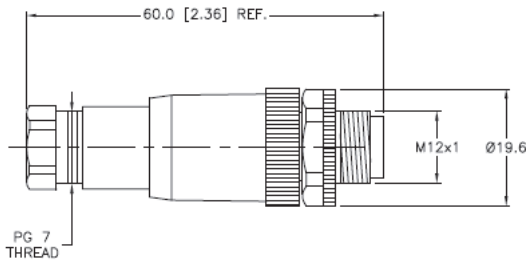

**Power Supply, 100-240VAC, +24VDC, M12 12-Pin Socket – 1 Meter – U.S. / Euro Plug**  
**97-000012-01**

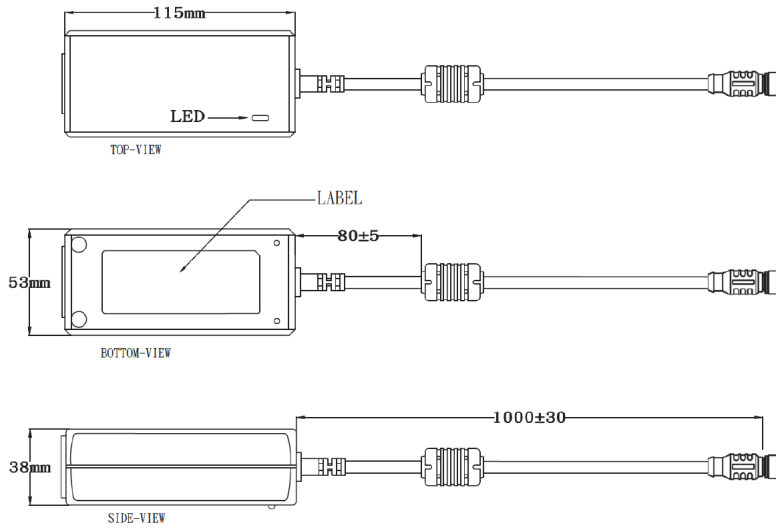



**Zapraszamy do kontaktu!**  
**Więcej informacji: [www.kreski.pl](http://www.kreski.pl)**

**Omron Microscan Smart Light Series – Integrated Power and Strobe Control Module**  
**See Omron Microscan Smart Light Offering – Ring, DOAL, Large Area Lighting**

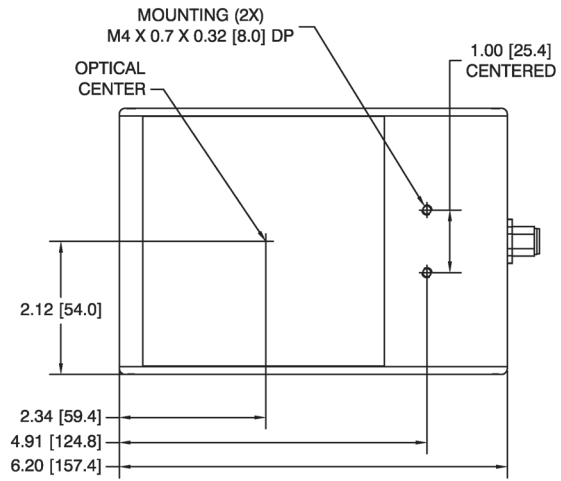
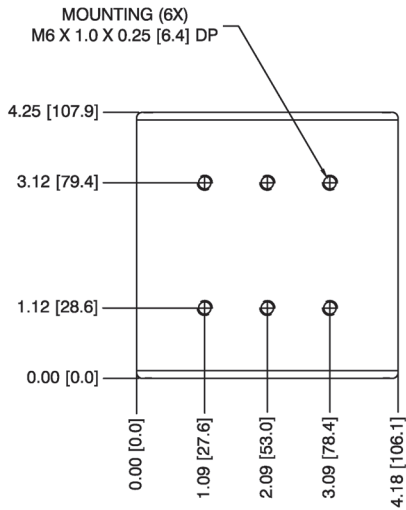
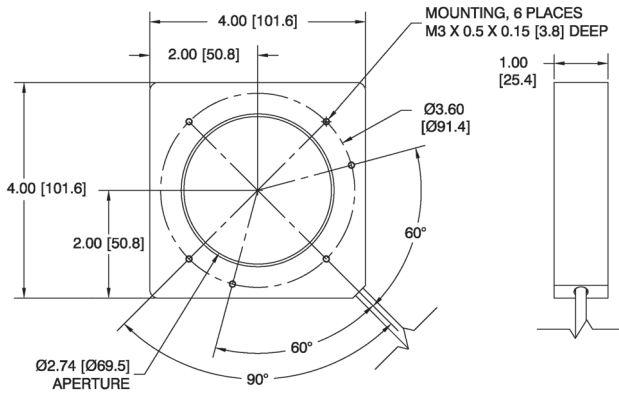

Zapraszamy do kontaktu!  
Więcej informacji: [www.kreski.pl](http://www.kreski.pl)

# V430-F

Ethernet Communication Cables – Straight Connectors – 1 Meter, 3 Meters, or 5 Meters

M12 Plug on Camera to RJ45 Connector

V430-WE-1M

V430-WE-3M

V430-WE-5M

**Kreski**  
Zapraszamy do kontaktu!  
Więcej informacji: [www.kreski.pl](http://www.kreski.pl)

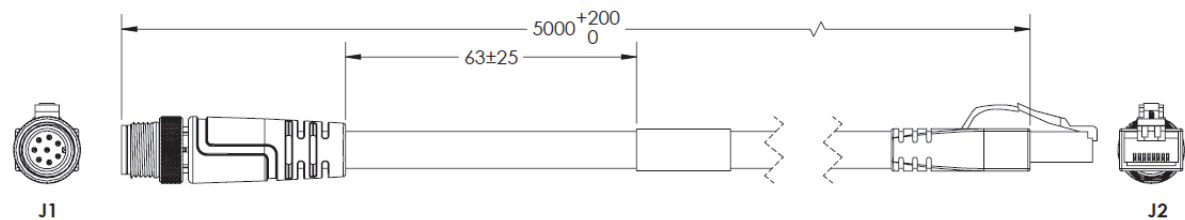
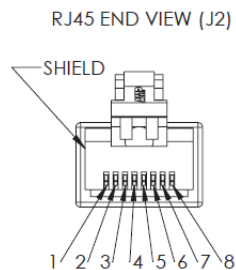
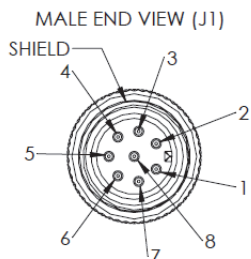
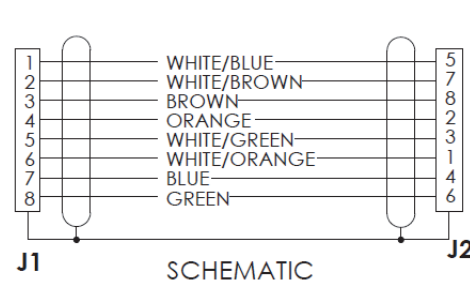
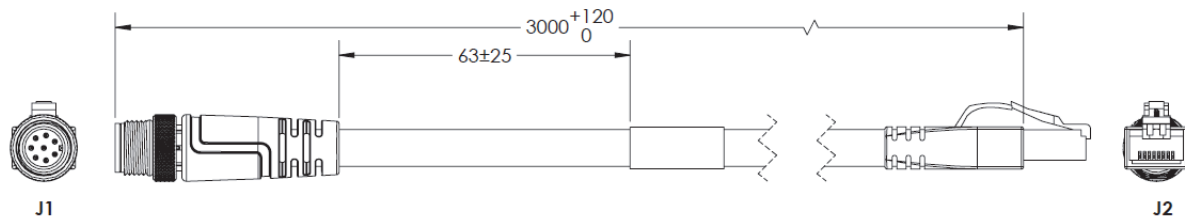
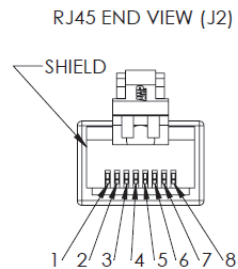
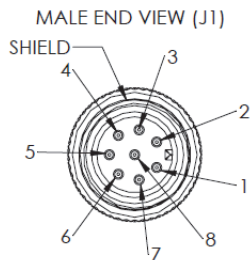
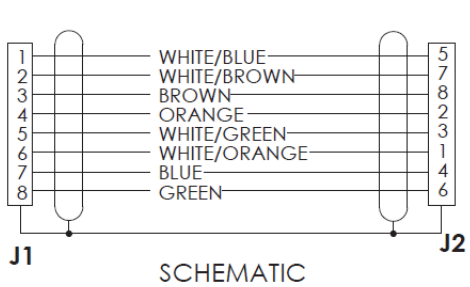
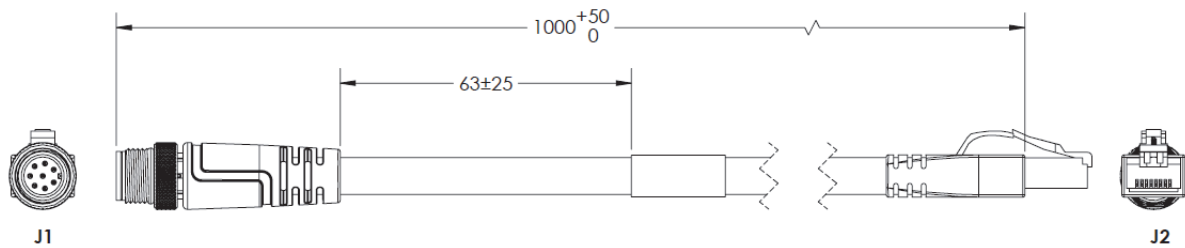
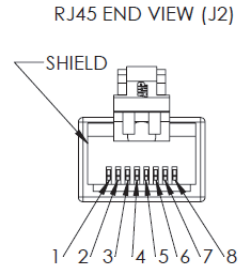
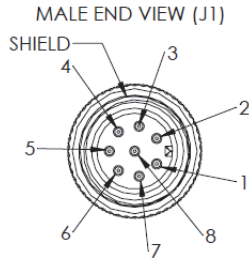
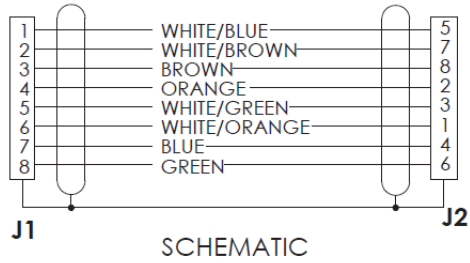

**Ethernet Communication Cables – Right Angle M12 Connectors – 3 Meters**  
**M12 Plug on Camera to RJ45 Connector**  
**V430-WELU-3M (Right Angle Up)\***  
**V430-WELD-3M (Right Angle Down)\***

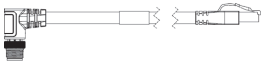

**\*Right angle up**

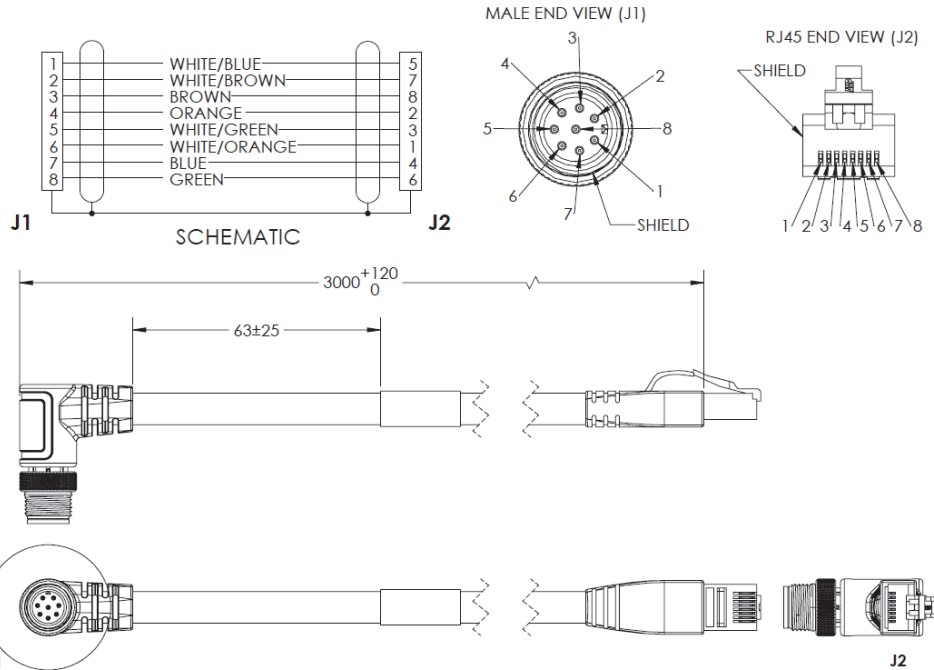

**\*Right angle down**

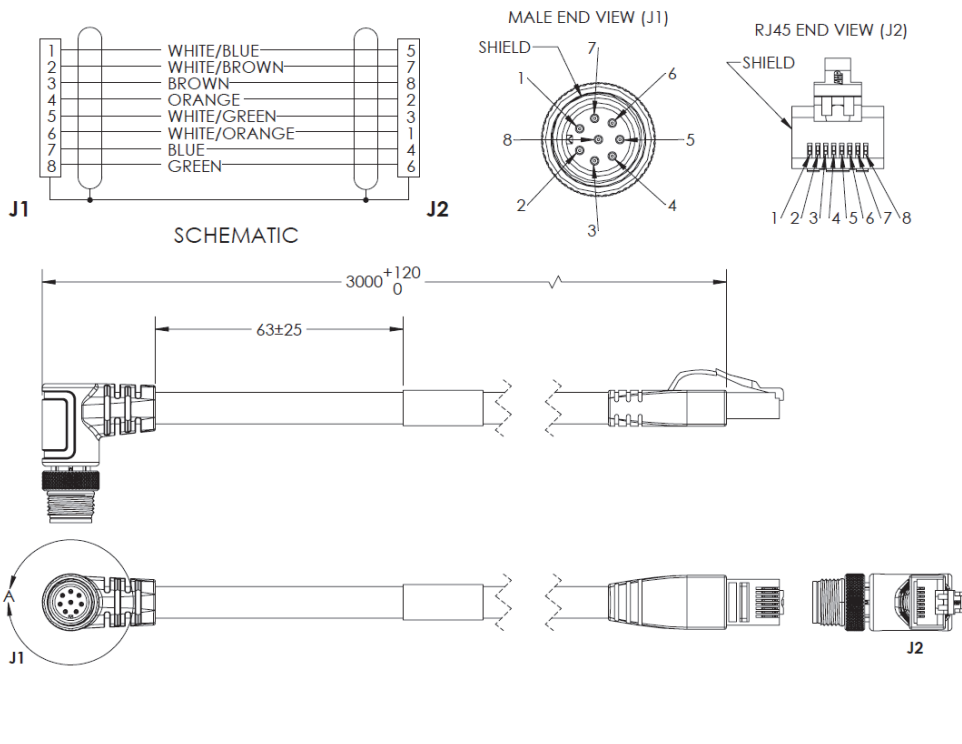

**Kreski**  
 Zapraszamy do kontaktu!  
 Więcej informacji: [www.kreski.pl](http://www.kreski.pl)

Camera to QX-1 Interconnect Cables – 1 Meter, 3 Meters, or 5 Meters  
 M12 Socket to M12 Plug  
 QX-1 is used as breakout module for common IO signals and power.  
 V430-WQ-1M  
 V430-WQ-3M  
 V430-WQ-5M

**Kreski**  
 Zapraszamy do kontaktu!  
 Więcej informacji: [www.kreski.pl](http://www.kreski.pl)

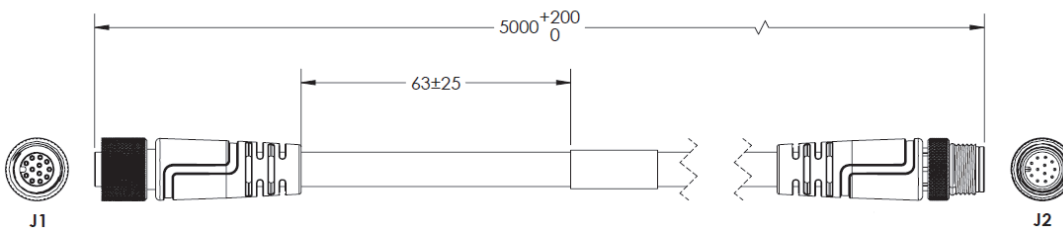
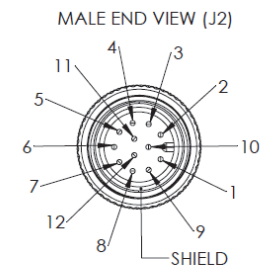
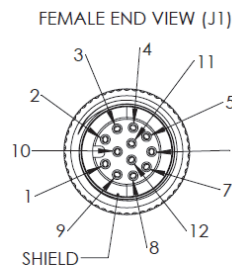
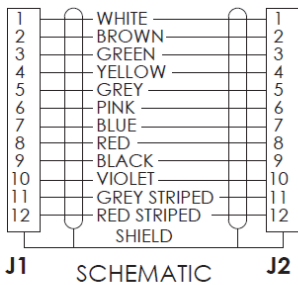
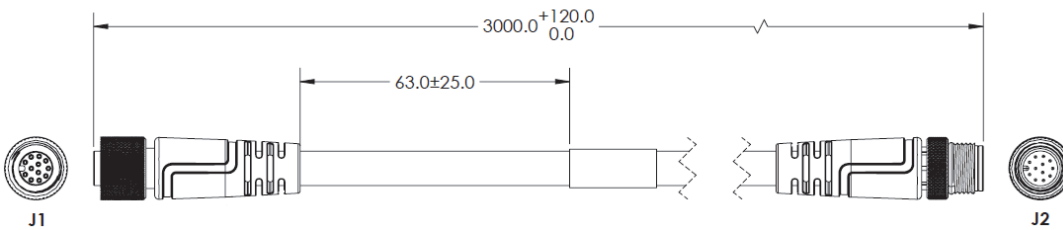
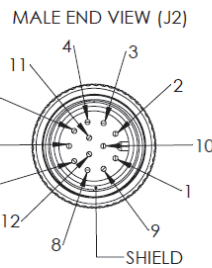
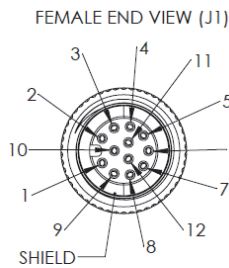
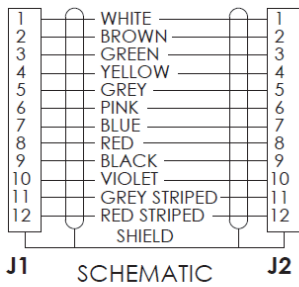
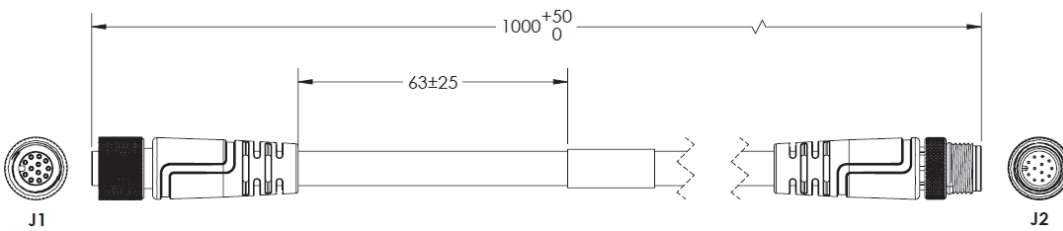
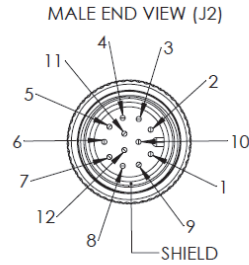
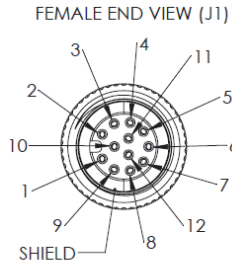
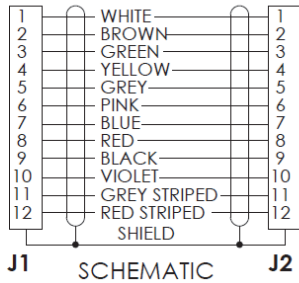

**M12 Socket to M12 Plug, with Power Filter – 300 mm  
V430-WQF-1M**

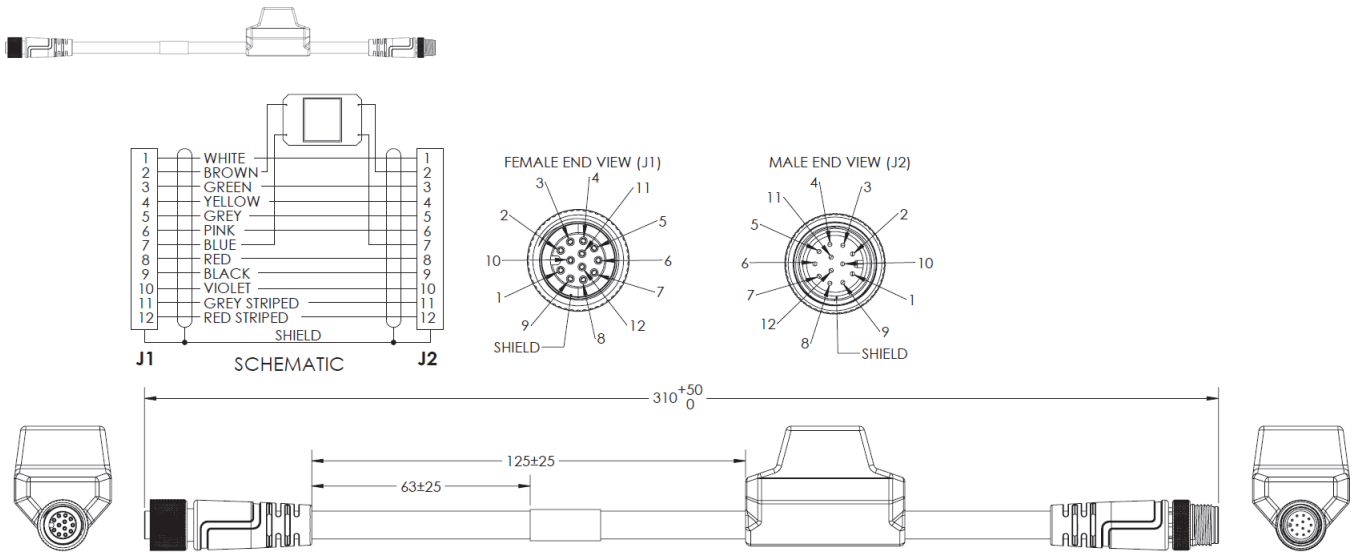

**QX-1 M12 to Smart Light Power and Strobe Control Cables – 3 Meters  
M12 Plug on QX-1 to 5 Pin Socket on Light  
61-000204-01 (Continuous Power)  
61-000218-01 (Strobe Control)**

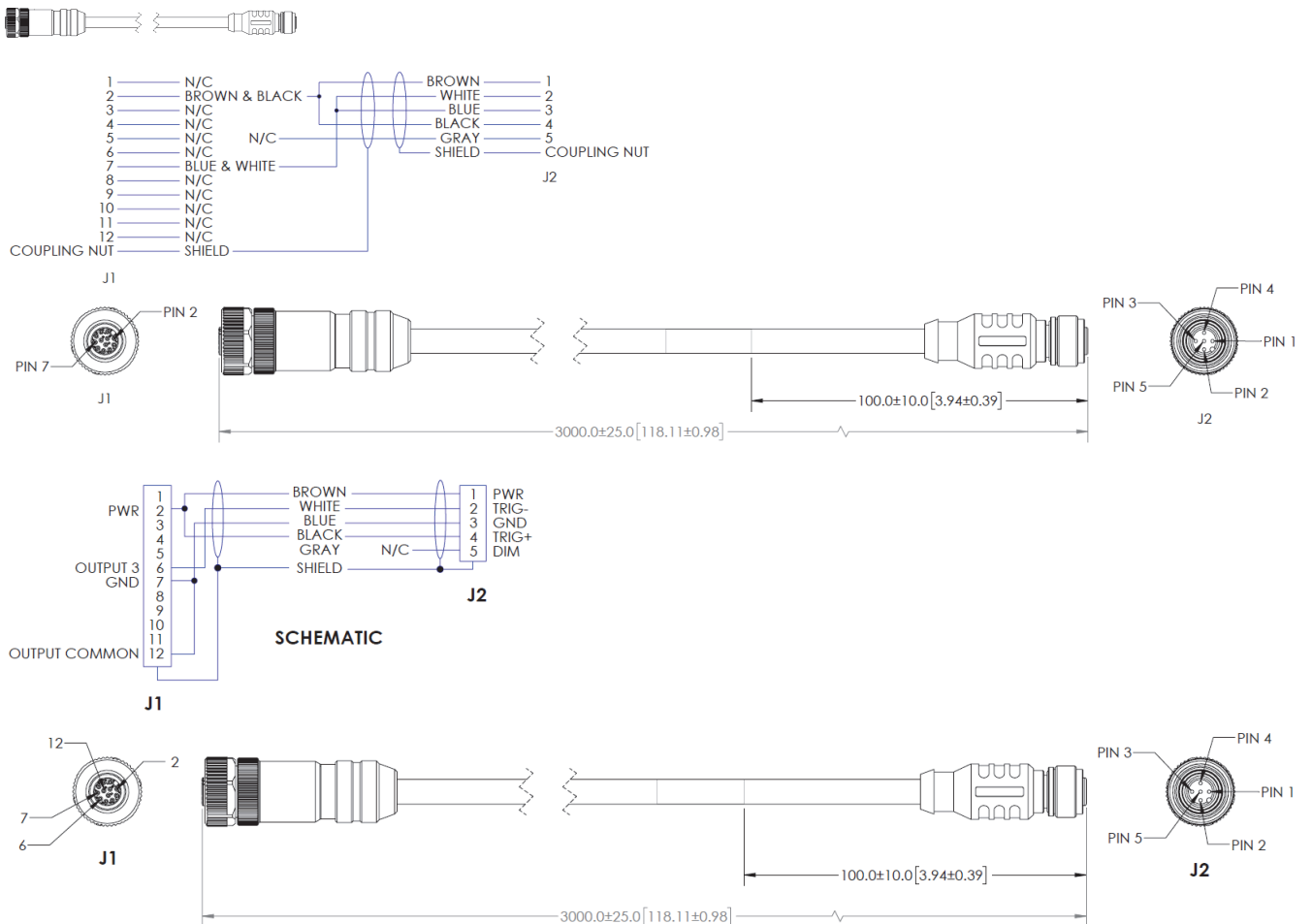

**Y Cable, Camera/Power and Smart Light Power (Continuous On) – 1 Meter**  
61-9000135-01

**Y Cable, Camera/Power and Smart Light Strobe Control – 1 Meter**  
61-9000137-01

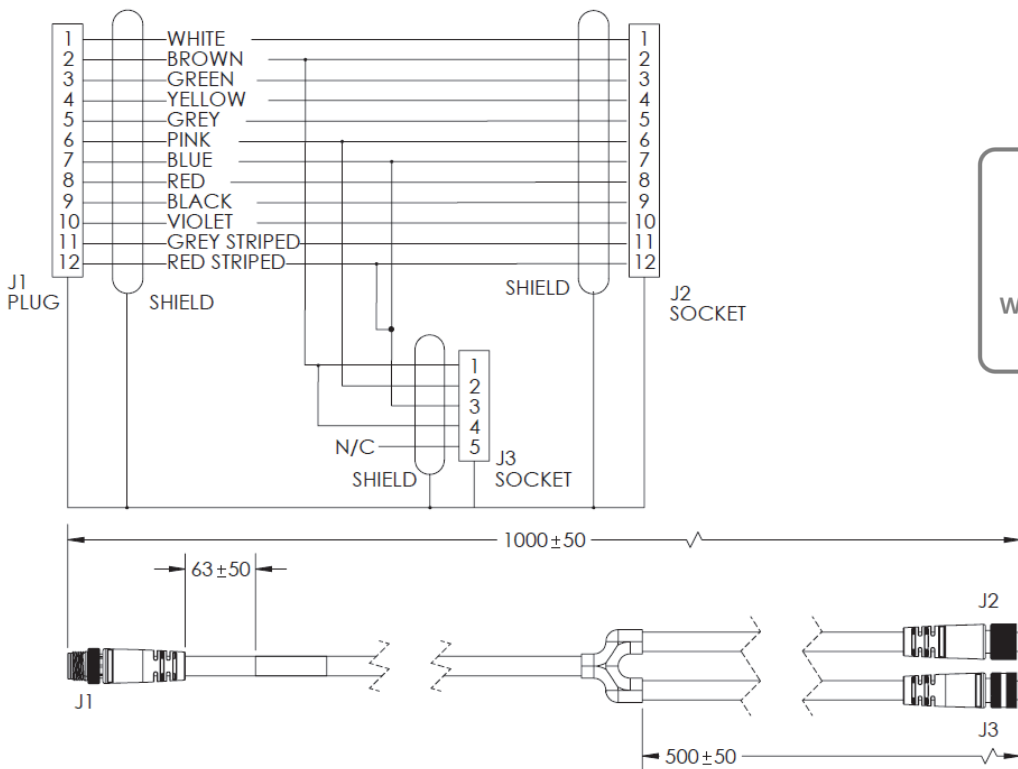
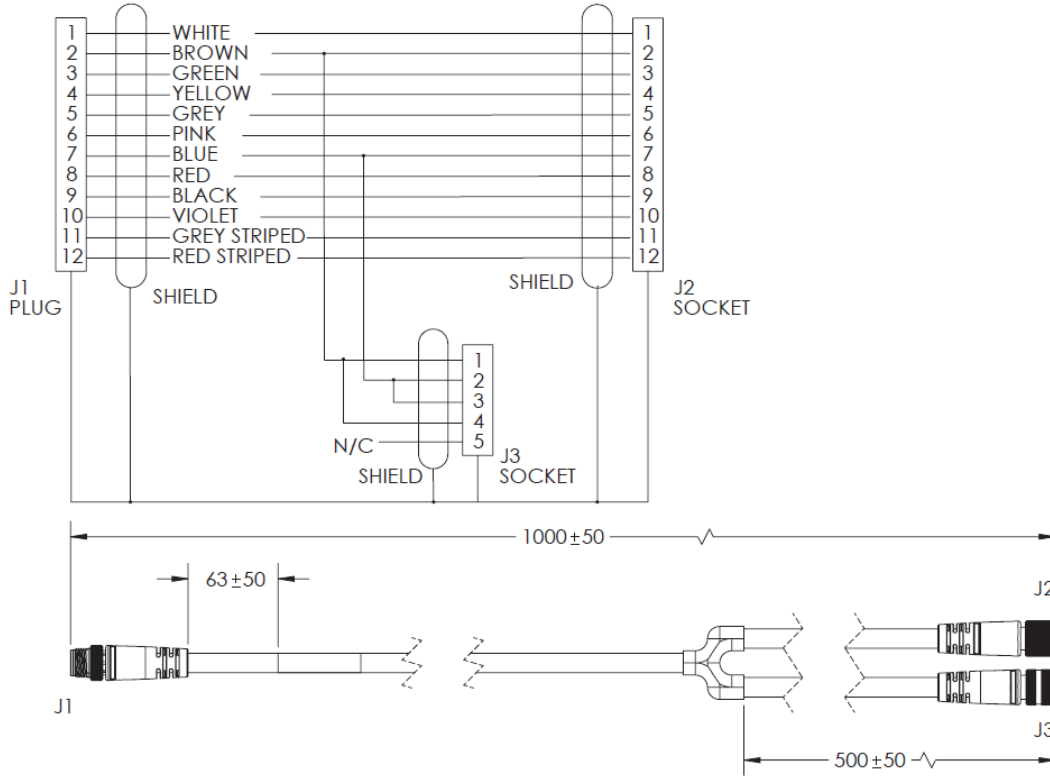
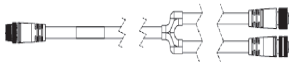

**Kreski**  
Zapraszamy do kontaktu!  
Więcej informacji: [www.kreski.pl](http://www.kreski.pl)



**M12 to Flying Leads Cable, Straight Power, IO, RS-232, USB – 3 Meters or 5 Meters**  
**V430-W8-3M**  
**V430-W8-5M**

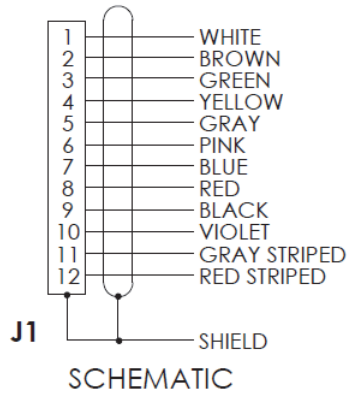
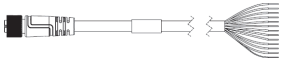

**FEMALE END VIEW (J1)**

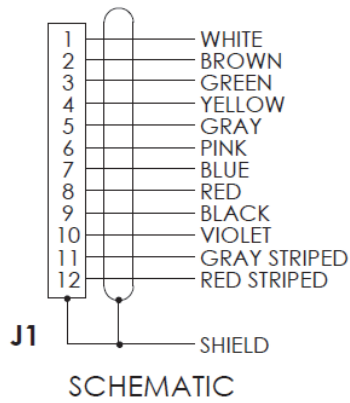
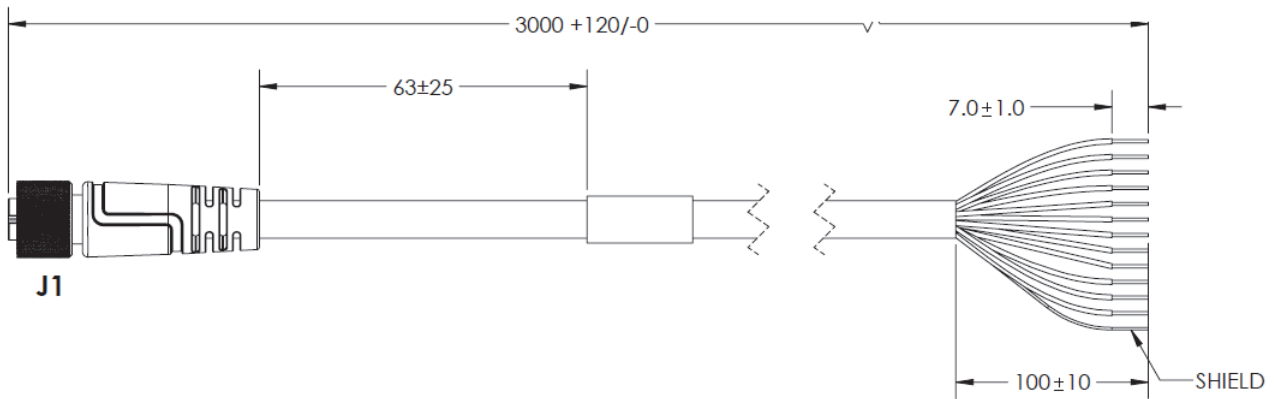
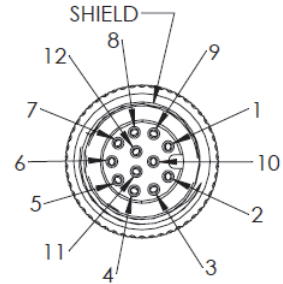

**FEMALE END VIEW (J1)**

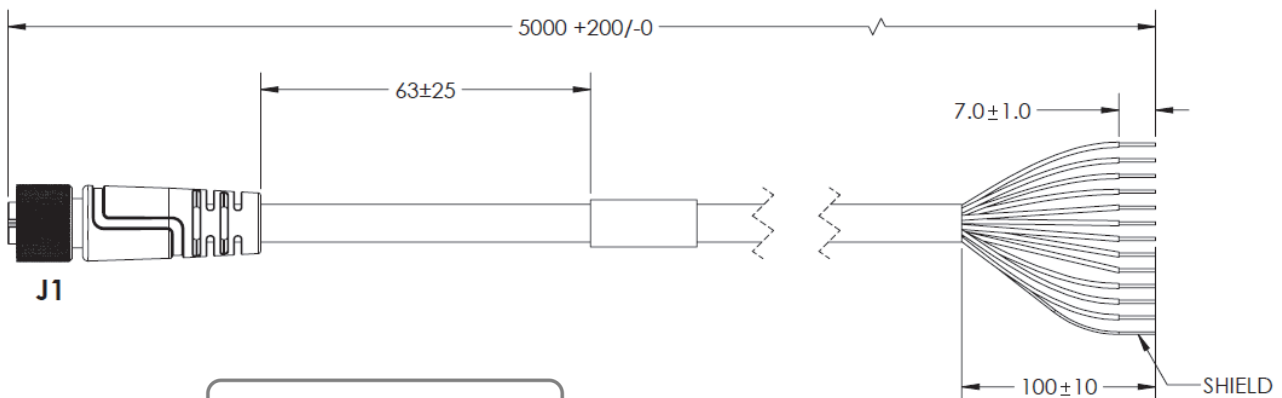
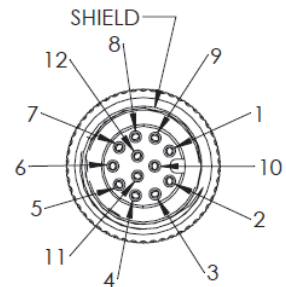

**Kreski**  
 Zapraszamy do kontaktu!  
 Więcej informacji: [www.kreski.pl](http://www.kreski.pl)

**M12 to Flying Leads Cable, with Power Filter – 3 Meters or 5 Meters**  
**V430-W8F-3M**  
**V430-W8F-5M**

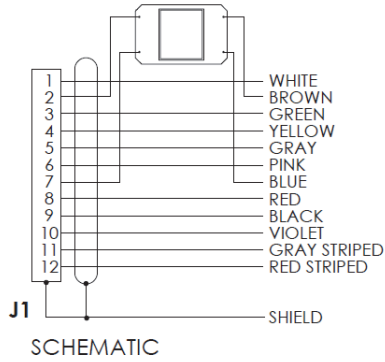
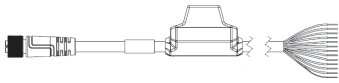

FEMALE END VIEW (J1)

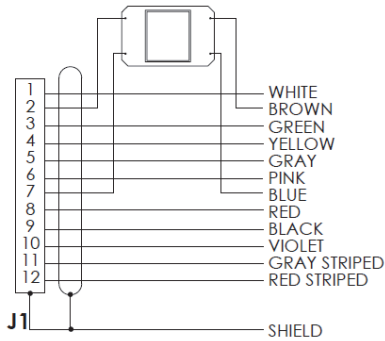
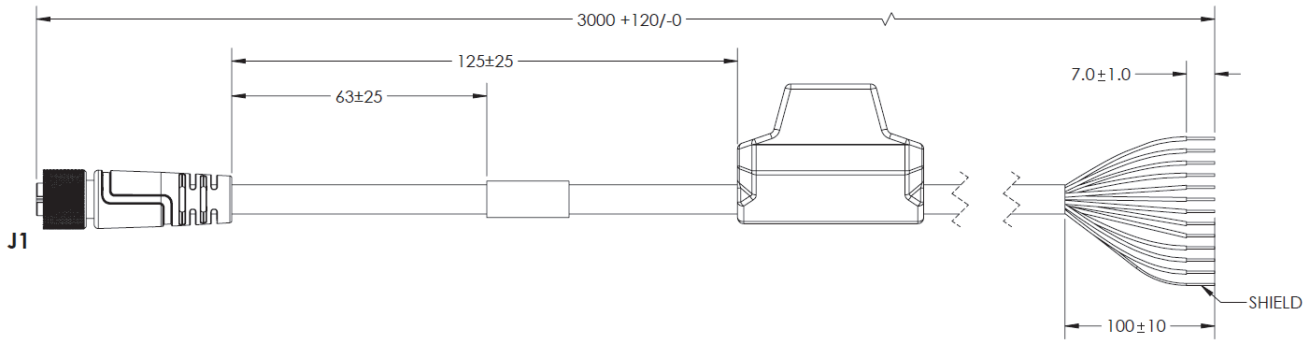
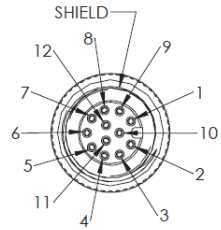

FEMALE END VIEW (J1)

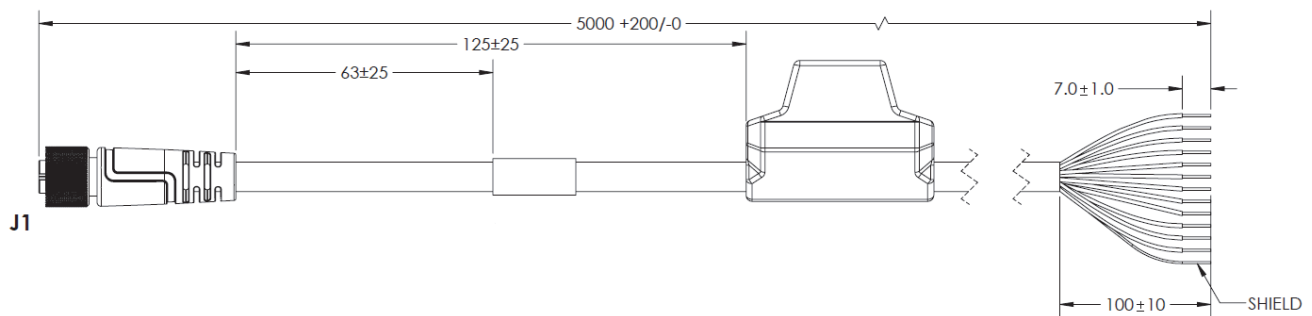
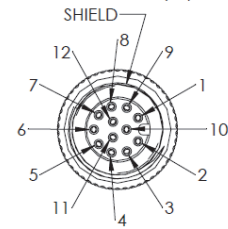

**Kreski**

Zapraszamy do kontaktu!  
 Więcej informacji: [www.kreski.pl](http://www.kreski.pl)

**M12 to Flying Leads Cable Right Angle Up Power, IO, RS232, USB – 3 Meters  
V430-W8LU-3M**

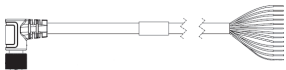

\*Right angle up

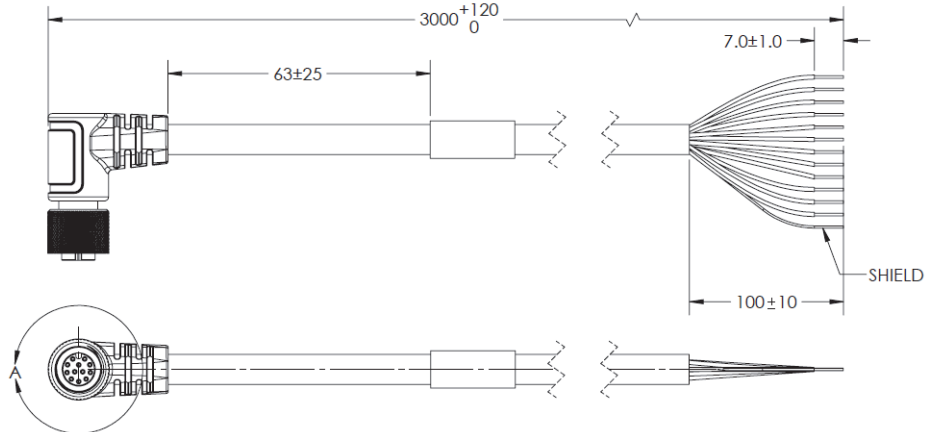
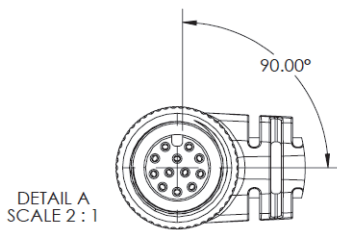
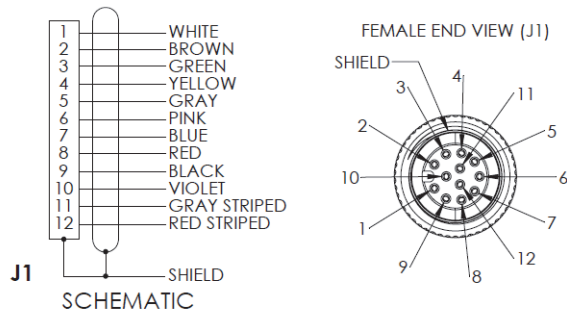

**M12 to Flying Leads Cable Right Angle Up, with Power Filter – 3 Meters  
V430-W8LUF-3M**

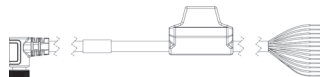

\*Right angle up

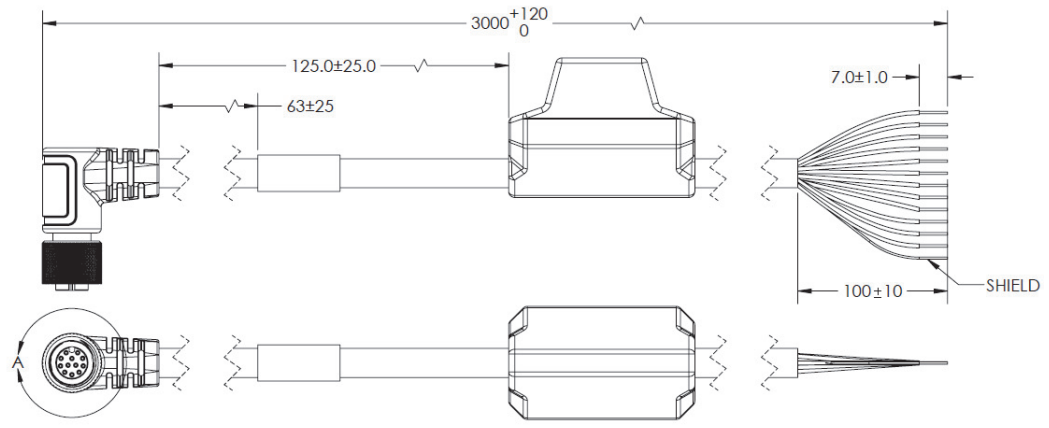
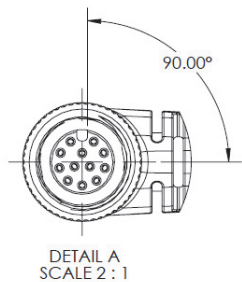
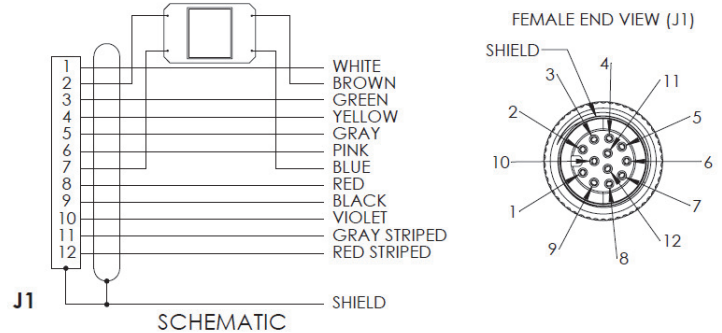

**Kreski**

Zapraszamy do kontaktu!  
Więcej informacji: [www.kreski.pl](http://www.kreski.pl)

**M12 to Flying Leads Cable Right Angle Down Power, IO, RS232, USB – 3 Meters  
V430-W8LD-3M**



\*Right angle down

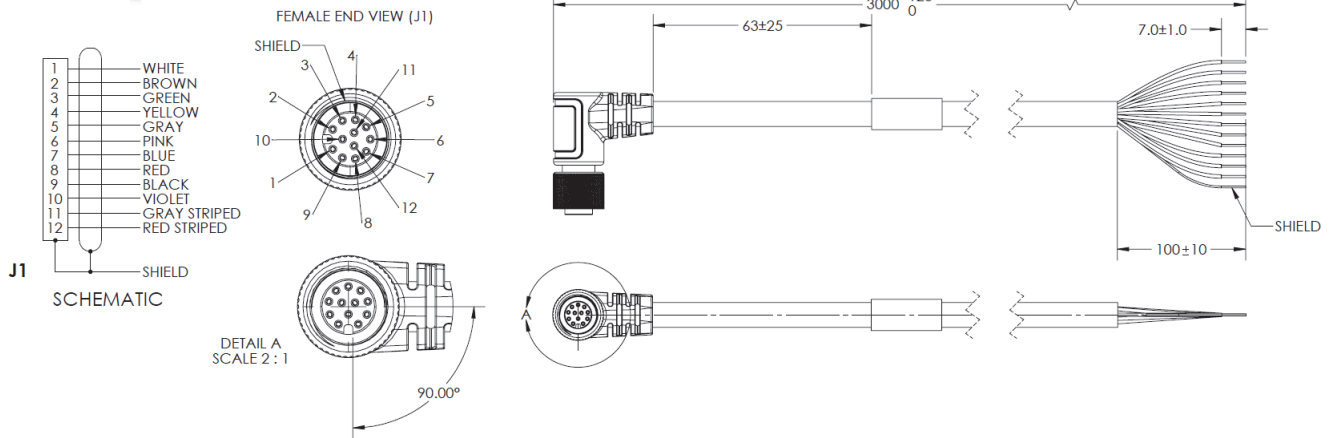

**M12 to Flying Leads Cable Right Angle Down, with Power Filter – 3 Meters  
V430-W8LDF-3M**

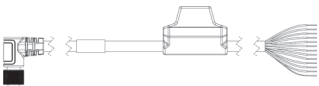

\*Right angle down

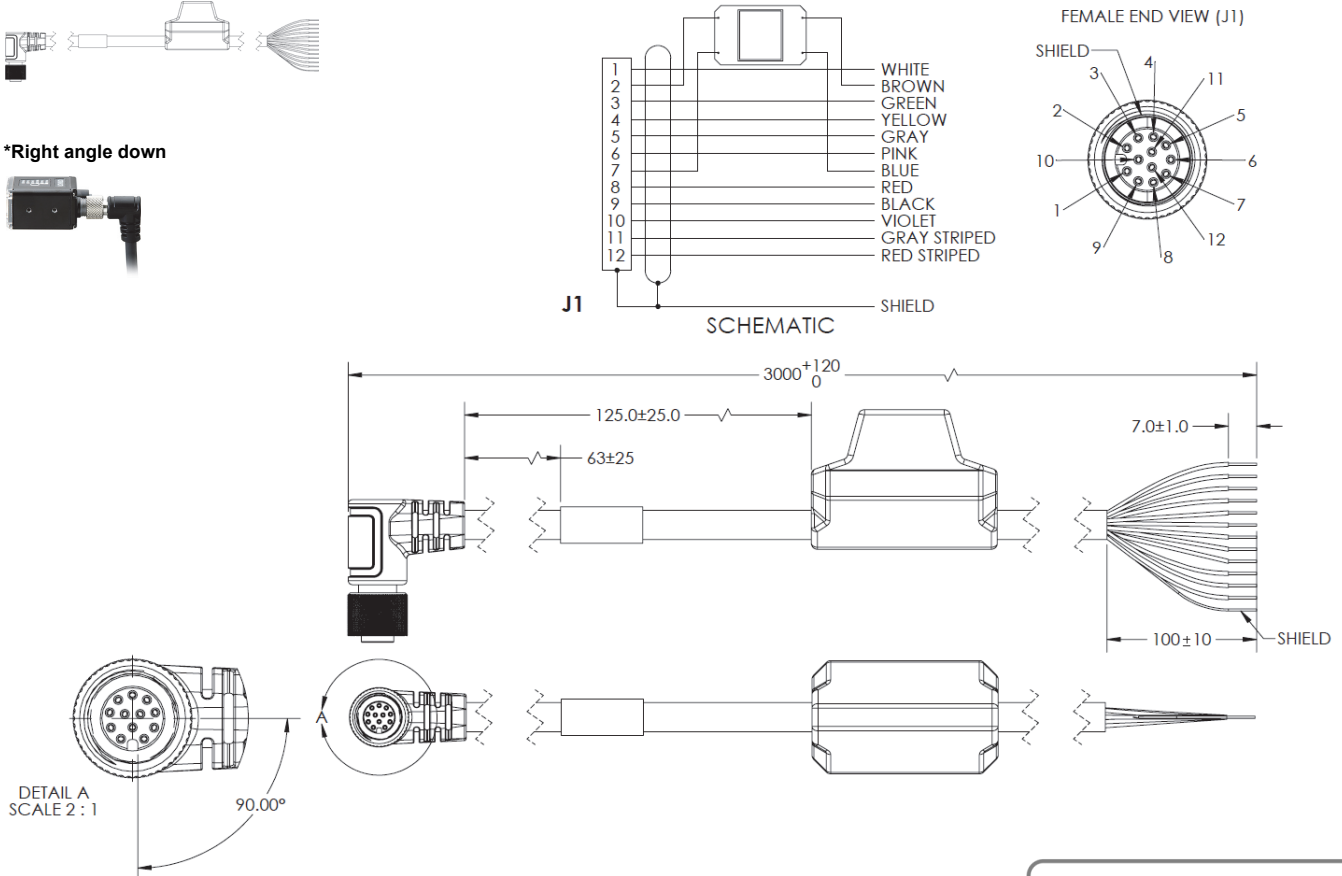

Zapraszamy do kontaktu!  
Więcej informacji: [www.kreski.pl](http://www.kreski.pl)

**M12 to RS-232 Breakout – 1 Meter or 3 Meters**  
**V430-WR-1M**  
**V430-WR-3M**

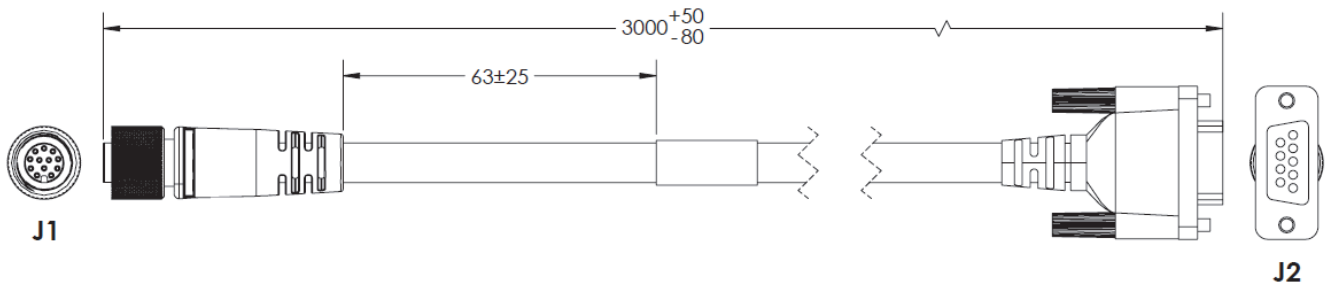
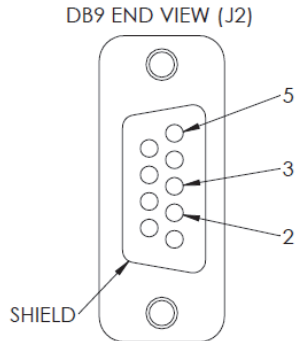
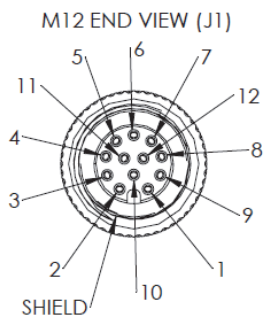
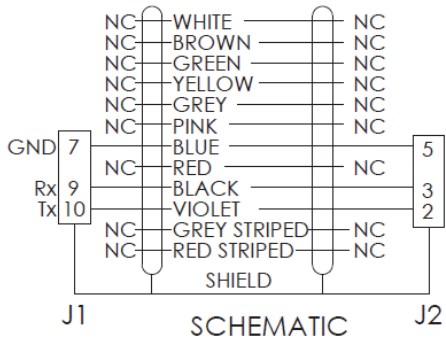
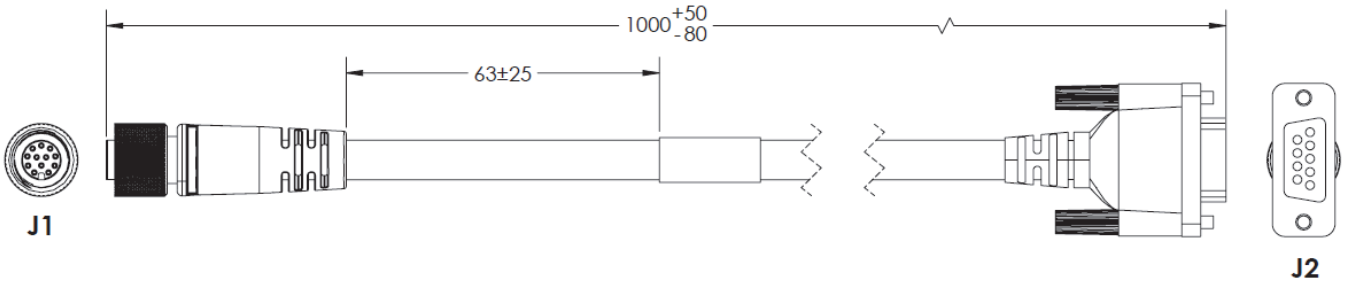
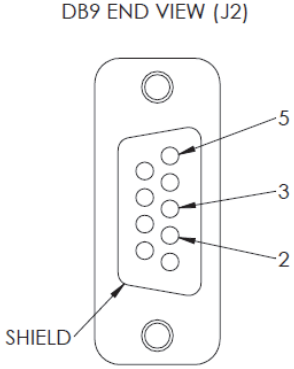
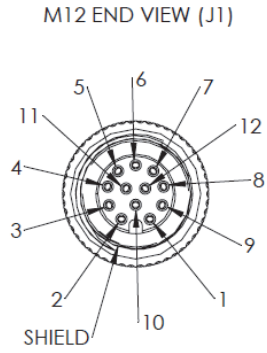
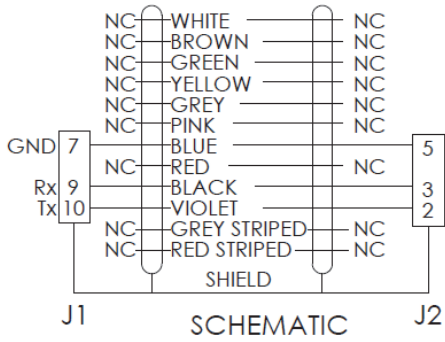

**Kreski**  
 Zapraszamy do kontaktu!  
 Więcej informacji: [www.kreski.pl](http://www.kreski.pl)

**Camera to QX-1 Interconnect Cables with RS-232 Breakout – 2.7 Meters**  
**V430-WQR-3M**

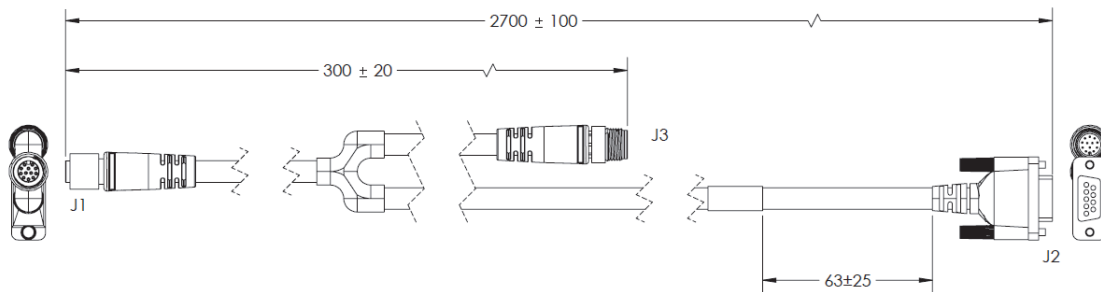
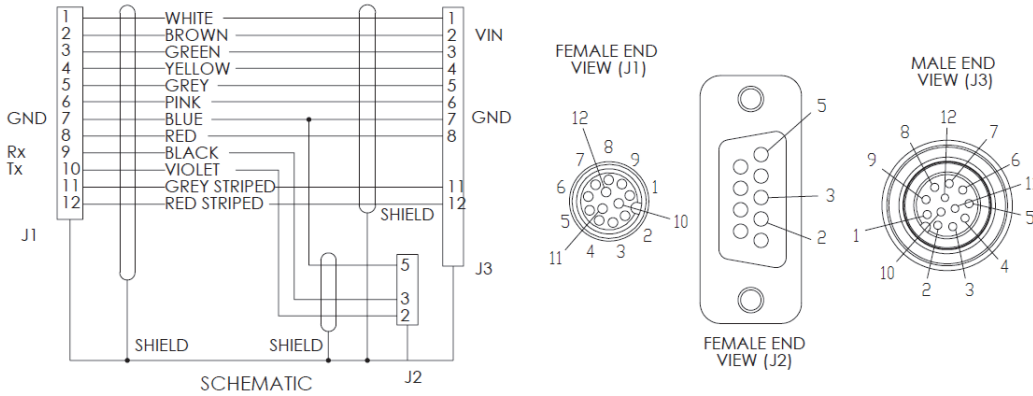
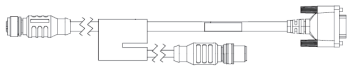

**Camera to QX-1 Interconnect Cables with USB Keyboard Wedge Breakout – 2.7 Meters**  
**V430-WQK-3M**

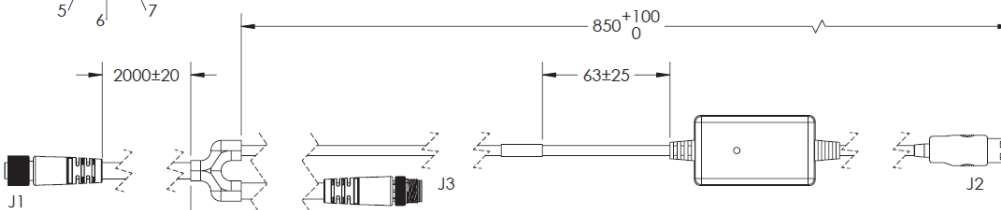
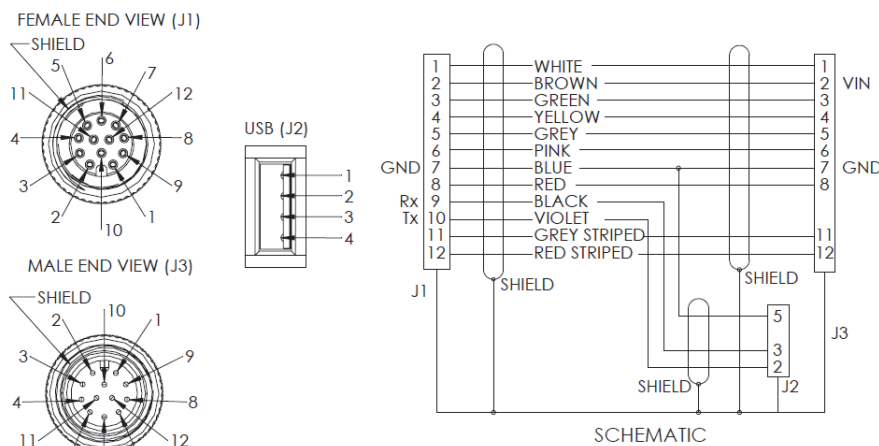
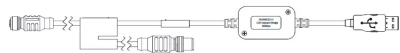

**M12 12-Pin Plug to M12 12-Pin Socket, Right Angle, 3 Meters**  
**61-000148-03**

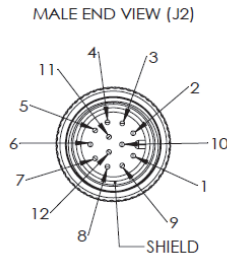
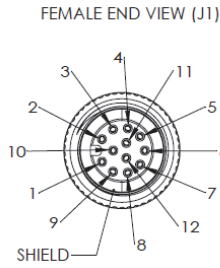
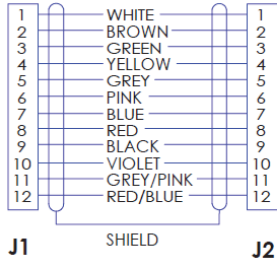
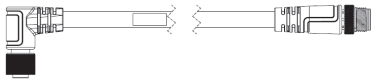

SCHEMATIC

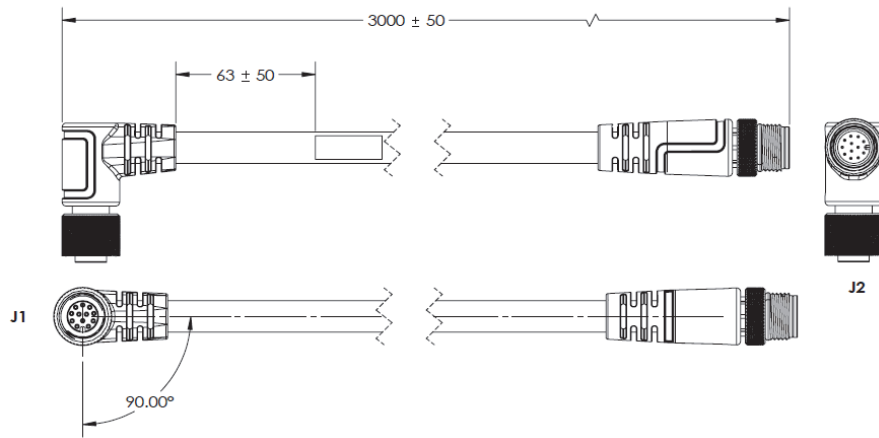

**M12 12-Pin Plug to M12 12-Pin Socket, Right Angle, Alternate Key, 3 Meters**  
**61-000148-04**

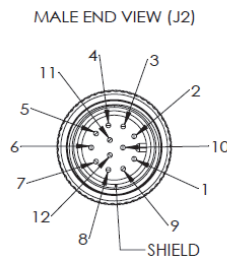
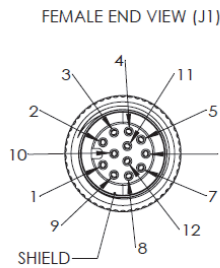
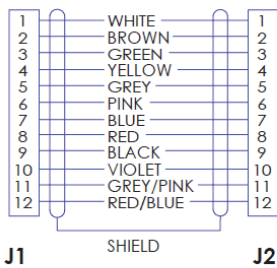
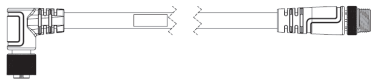

SCHEMATIC

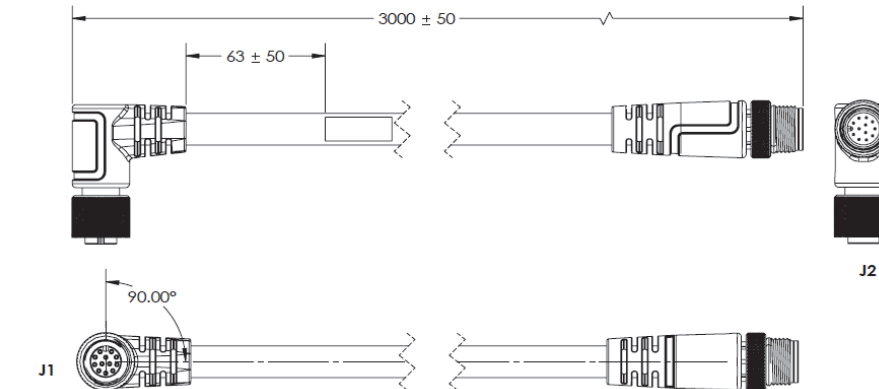

**Kreski**  
 Zapraszamy do kontaktu!  
 Więcej informacji: [www.kreski.pl](http://www.kreski.pl)

**M12 12-Pin Plug to M12 12-Pin Socket, Right Angle, 1 Meter**  
**61-000162-03**

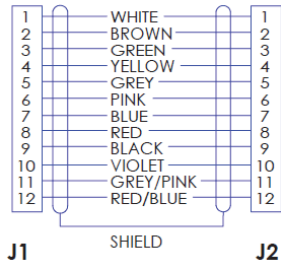

FEMALE END VIEW (J1)

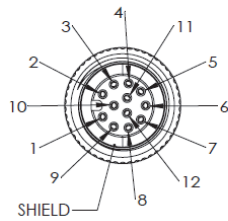

MALE END VIEW (J2)

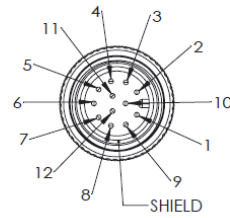

SCHEMATIC

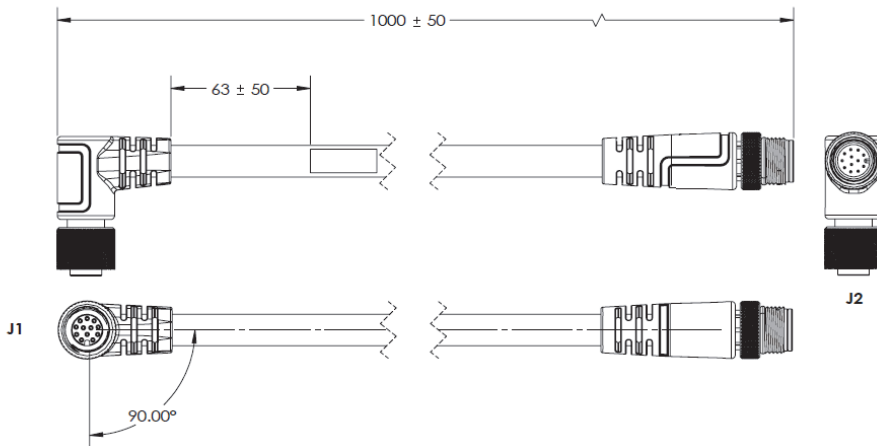

**M12 12-Pin Plug to M12 12-Pin Socket, Right Angle, Alternate Key, 1 Meter**  
**61-000162-04**

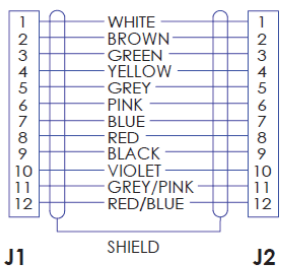
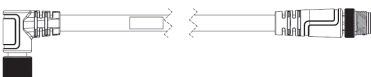

FEMALE END VIEW (J1)

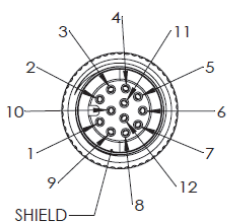

MALE END VIEW (J2)

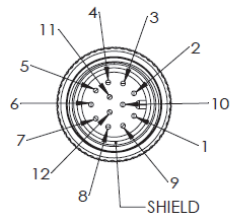

SCHEMATIC

